



LITEMAX DLF/DLH2415 Sunlight Readable 24" LED B/L LCD

User Manual

(2st Edition 2010/11/12)

All information is subject to change without notice.

| Approved by | Checked by | Prepared by |
|-------------|------------|-------------|
| Ming | Jacky | Max |

LITEMAX Electronics Inc.

8F, No.137, Lane 235, Bau-chiau Rd.,
Shin-dian City, Taipei County, Taiwan R.O.C.
Tel : 886-2-8919-1858
Fax: 886-2-8919-1300
Homepage: <http://www.litemax.com.tw>

RECORD OF REVISION

| Version and Date | Page | Old Description | New Description | Remark |
|------------------|------|-----------------|----------------------------------|--------|
| Aug,2,2010 | all | | Preliminary Release | |
| Aug,24,2010 | all | | Update data of LED driving Board | |
| Nov,12,2010 | all | | Update page 13/14 data | |
| | | | | |
| | | | | |
| | | | | |

Contents

| | |
|---|-----------|
| RECORD OF REVISION | 2 |
| Contents | 3 |
| 1.0 GENERAL DESCRIPTION | 4 |
| 1.1 FEATURES | 4 |
| 1.2 GENERAL SPECIFICATIONS | 4 |
| 1.3 ABSOLUTE MAXIMUM RATINGS | 4 |
| 2.0 Electrical characteristics | 6 |
| 3.0 SIGNAL Characteristic | 8 |
| 4.0 TIMING Characteristics | 11 |
| 5.0 CONNECTOR and PIN ASSIGNMENT | 13 |
| 6.0 OPTICAL SPECIFICATION | 15 |
| 7.0 MEASURING METHOD | 16 |
| 8.0 LED DRIVING BOARD SPECIFICATIONS | 19 |
| 9.0 AD2662GDVAR SPECIFICATIONS(DLH2415 only) | 23 |
| 9.1 General Description | 23 |
| 9.2 Outline Dimensions | 24 |
| 9.3 AD2662 Board Pin Define | 27 |
| J3: Panel connector..... | 27 |
| CN3: DVI-D INPUT Connector | 27 |
| CN5: DVI-D Connector (16pin 2.0mm)..... | 28 |
| CN2: Analog RGB Input connector (D-SUB 15Pin) | 28 |
| CN4: Analog RGB Input connector (13pin connector) | 28 |
| JS1: Power DIN(12V)..... | 28 |
| JS1: Power Jack (12V)..... | 28 |
| J1: Power connector (12V) (6PIN 2.0mm) | 29 |
| J8: Power connector (5V/12v)(4PIN 2.0mm) | 29 |
| J2: Inverter Connector(8PIN 2.0mm)..... | 29 |
| J7, J9: FAN (2PIN 2.0mm)..... | 29 |
| J6: Key Pad (9PIN 2.0mm) | 29 |
| J10: Speaker Connector (4PIN 2.0mm) | 29 |
| J11 Extern Funtion Connector (11P X 2PIN 2.0mm)..... | 30 |
| J5: Ambient (3PIN 2.0mm) | 30 |
| J4: VR connector (3PIN 2.0mm) | 30 |
| J12: IR Connector(3PIN 2.0mm)..... | 30 |
| JP1: PANEL VCC (3PIN 2.54mm) | 30 |
| 9.4 I/O BOARD Pin Define | 31 |
| 9.5 IR Receive Board Pin Define | 32 |
| 9.6 DC Characteristics | 32 |
| 9.7 OSD menu | 33 |
| 10.0 MECHANICAL DRAWING | 38 |
| 11.0 PRECAUTIONS | 40 |

1.0 GENERAL DESCRIPTION

DLF/DLH2415 is AUO 24" wide color TFT-LCD module as active switching devices with 1,000nits LED backlight powered by Durapixel™ technology. This module has a 24 inch diagonally measured active area with Full HD resolutions (1920 horizontal by 1080 vertical pixel array). Each pixel is divided into RED, GREEN, BLUE dots which are arranged in vertical stripe and this module can display 16.7M colors.

1.1 FEATURES

- Sunlight Readable
- LED Backlight
- WUXGA(1920x1080) High Definition
- High Shock & Vibration Resistance
- Low Power Consumption
- Wide Operation Temperature.
- High Uniformity (90%)
- Low EMI Noise
- Wide Dimming
- Life Expectancy (70,000hrs)

1.2 GENERAL SPECIFICATIONS

| | |
|-------------------------|--|
| Description | 24" TFT LCD, LED Backlight 1000nits, FHD |
| Display Area (mm) | 531.4 x 298.9 mm |
| Brightness | 1000 cd/m ² |
| Resolution | 1920x1080 |
| Contrast Ratio | 1000 : 1 |
| Pixel Pitch (mm) | 0.270(H) x 0.270(V) |
| Viewing Angle | +85°~ -85°(H), +80°~ -80°(V) |
| Display Colors | 16.7M |
| Response Time (Typical) | 6.5ms |
| Sync | LVDS |
| Power Consumption | 38W |
| Dimensions (mm) | 556x323.2x12.5 mm |
| Weight (Net) | 2.67kg |

1.3 ABSOLUTE MAXIMUM RATINGS

TFT LCD Module

| Item | Symbol | Min | Max | Unit | Conditions |
|-------------------------|--------|-----|-----|--------|-----------------|
| Logic/LCD Drive Voltage | VDD | 0 | 6.0 | [Volt] | <i>Note 1,2</i> |

ABSOLUTE RATINGS OF ENVIRONMENT

| Item | Symbol | Min. | Max. | Unit | Conditions |
|-----------------------|--------|------|------|-------|---------------|
| Operating Temperature | TOP | 0 | +50 | [°C] | Note 3 |
| Operation Humidity | HOP | 5 | 90 | [%RH] | |
| Storage Temperature | TST | -20 | +60 | [°C] | |
| Storage Humidity | HST | 5 | 90 | [%RH] | |

Note 1: With in Ta (25°C)

Note 2: Permanent damage to the device may occur if exceeding maximum values

Note 3: For quality performance, please refer to AUO IIS(Incoming Inspection Standard).

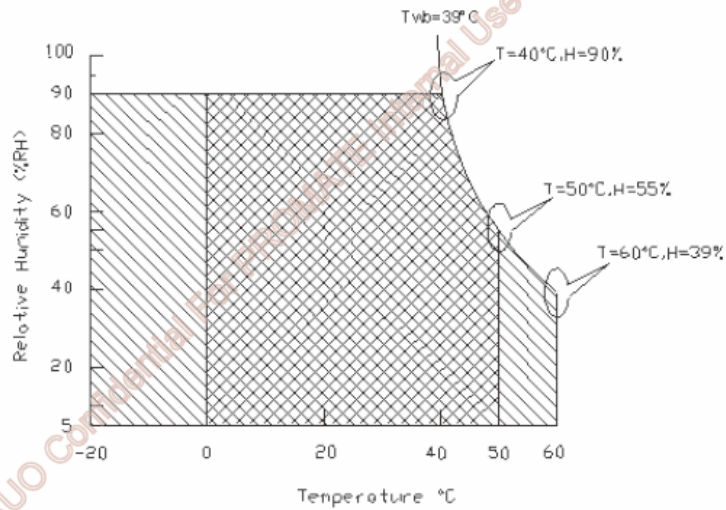

Operating Range



Storage Range

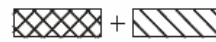

2.0 Electrical characteristics

TFT LCD Module Power Specification

Input power specifications are as following:

| Symbol | Parameter | Min | Typ | Max | Unit | Conditions |
|--------|--|-----|-----|-----|----------|---------------------------------------|
| VDD | Logic/LCD Drive Voltage | 4.5 | 5.0 | 5.5 | [Volt] | +/-10% |
| IDD | Input Current | - | 0.6 | 1.2 | [A] | VDD= 5.0V, All black Pattern, At 60Hz |
| PDD | VDD Power | - | 3 | 6 | [Watt] | VDD= 5.0V, All black Pattern, At 60Hz |
| IRush | Inrush Current | - | - | 3 | [A] | Note 1 |
| VDDrp | Allowable Logic/LCD Drive Ripple Voltage | - | - | 300 | [mV] p-p | VDD= 5.0V, All Black Pattern At 75Hz |

Note 1: Measurement conditions:

The duration of rising time of power input is 470us.

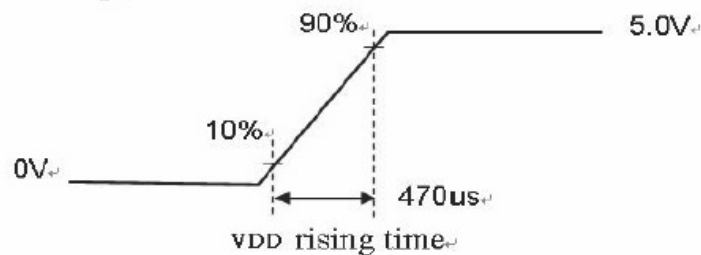
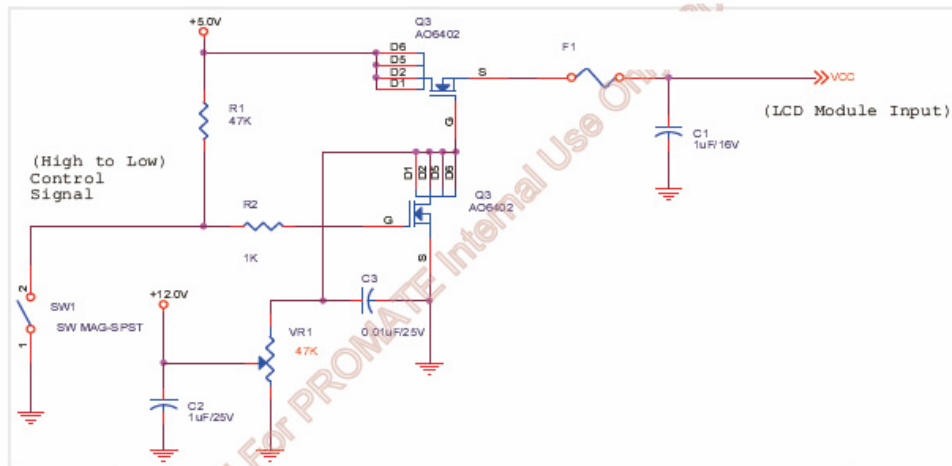

Signal Electrical Characteristics

Input signals shall be low or Hi-Z state when VDD is off. Please refer to specifications of SN75LVDS82DGG (Texas Instruments) in detail.

Characteristics of each signal are as following:

| Symbol | Parameter | Min | Typ | Max | Units | Condition |
|--------|--|------|------|------|-------|--|
| VTH | Differential Input High Threshold | - | +50 | +100 | [mV] | VICM = 1.2V Note 1 |
| VTL | Differential Input Low Threshold | -100 | -50 | - | [mV] | VICM = 1.2V Note 1 |
| VID | Input Differential Voltage | 100 | - | 600 | [mV] | Note 1 |
| VICM | Differential Input Common Mode Voltage | +1.0 | +1.2 | +1.5 | [V] | VTH-VTL = 200mV (max) Note 1 |

Note 1: LVDS Signal Waveform

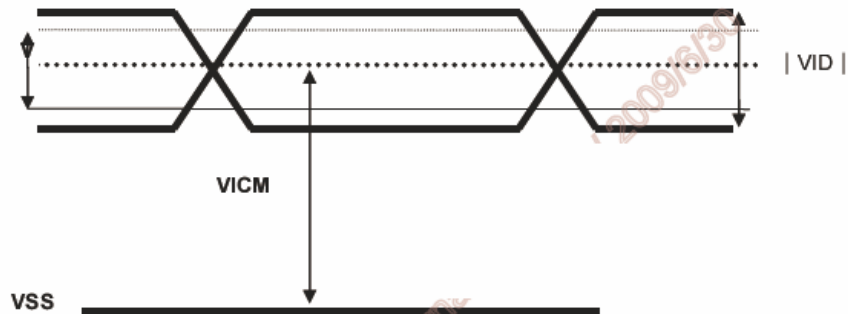

Backlight Unit Specification

Parameter guideline is under stable conditions at 25°C (Room Temperature):

| Symbol | Parameter | Min. □ | Typ. | Max. | Unit | Note |
|-------------------|---|--------|--------|-------|--------|---|
| IR _{LED} | LED Operation Current | - | 20 | 20 | [mA] | Operating with fixed driving current |
| V _{LB} | Light Bar Operation Voltage (for reference) | - | 42.9 | 44.2 | [Volt] | |
| P _{BLU} | BLU Power consumption (for reference) | - | 13.73 | 14.14 | [Watt] | |
| LT _{LED} | LED life Time | - | 15,000 | - | [Hour] | |

3.0 SIGNAL Characteristic

PIXEL FORMAT IMAGE

Following figure shows the relationship of the input signals and LCD pixel format.

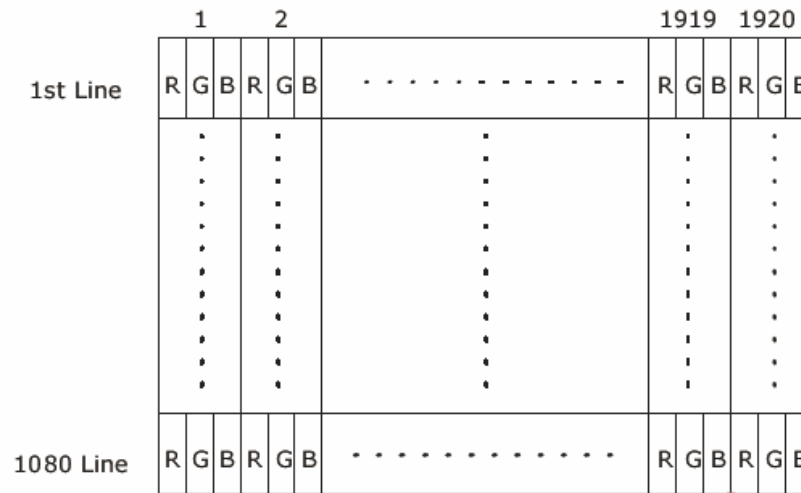

INPUT DATA FORMAT

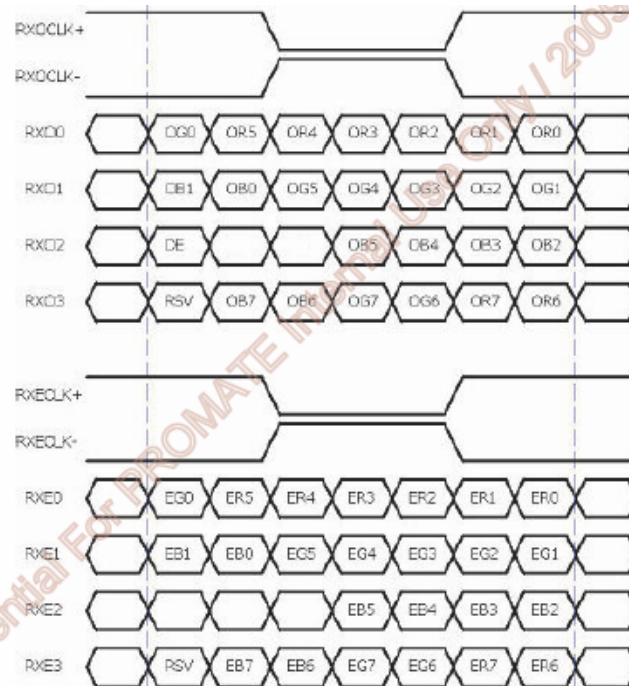

Note 1: R/G/B data 7:MSB, R/G/B data 0:LSB O = "Odd Pixel Data" E = "Even Pixel Data"

Signal Description

The module using one LVDS receiver SN75LVDS82(Texas Instruments). LVDS is a differential signal technology for LCD interface and high speed data transfer device. LVDS transmitters shall be SN75LVDS83(negative edge sampling). The first LVDS port(RxOxxx) transmits odd pixels while the second LVDS port(RxExxx) transmits even pixels.

| PIN # | SIGNAL NAME | DESCRIPTION |
|-------|-------------|--|
| 1 | RxOIN0- | Negative LVDS differential data input (Odd data) |
| 2 | RxOIN0+ | Positive LVDS differential data input (Odd data) |
| 3 | RxOIN1- | Negative LVDS differential data input (Odd data) |
| 4 | RxOIN1+ | Positive LVDS differential data input (Odd data) |
| 5 | RxOIN2- | Negative LVDS differential data input (Odd data, DSPTMG) |
| 6 | RxOIN2+ | Positive LVDS differential data input (Odd data, DSPTMG) |
| 7 | GND | Power Ground |
| 8 | RxOCLK- | Negative LVDS differential clock input (Odd clock) |
| 9 | RxOCLK+ | Positive LVDS differential clock input (Odd clock) |
| 10 | RxOIN3- | Negative LVDS differential data input (Odd data) |
| 11 | RxOIN3+ | Positive LVDS differential data input (Odd data) |
| 12 | RxEIN0- | Negative LVDS differential data input (Even data) |
| 13 | RxEIN0+ | Positive LVDS differential data input (Even data) |
| 14 | GND | Power Ground |
| 15 | RxEIN1- | Negative LVDS differential data input (Even data) |
| 16 | RxEIN1+ | Positive LVDS differential data input (Even data) |
| 17 | GND | Power Ground |
| 18 | RxEIN2- | Negative LVDS differential data input (Even data) |
| 19 | RxEIN2+ | Positive LVDS differential data input (Even data) |
| 20 | RxECLK- | Negative LVDS differential clock input (Even clock) |
| 21 | RxECLK+ | Positive LVDS differential clock input (Even clock) |
| 22 | RxEIN3- | Negative LVDS differential data input (Even data) |
| 23 | RxEIN3+ | Positive LVDS differential data input (Even data) |
| 24 | GND | Power Ground |
| 25 | NC | No connection (for AUO test only. Do not connect) |
| 26 | NC | No connection (for AUO test only. Do not connect) |
| 27 | VDD | Power +5V |
| 28 | VDD | Power +5V |
| 29 | VDD | Power +5V |
| 30 | VDD | Power +5V |

Note1: Start from left side

- Note :
1. THE DIMENSION EXCLUDES DEFORMATION.
 2. MODULE THICKNESS TO BE 13.2 MAX.
 3. LED BULB CONNECTOR : HD2505-02 OR COMPATIBLE
 4. I/F CONNECTOR TO BE JAE FI-XB30SR-HF11 OR COMPATIBLE
 5. M3 USER HOLE SCREW TORQUE 5.0 kgf-cm MAX.

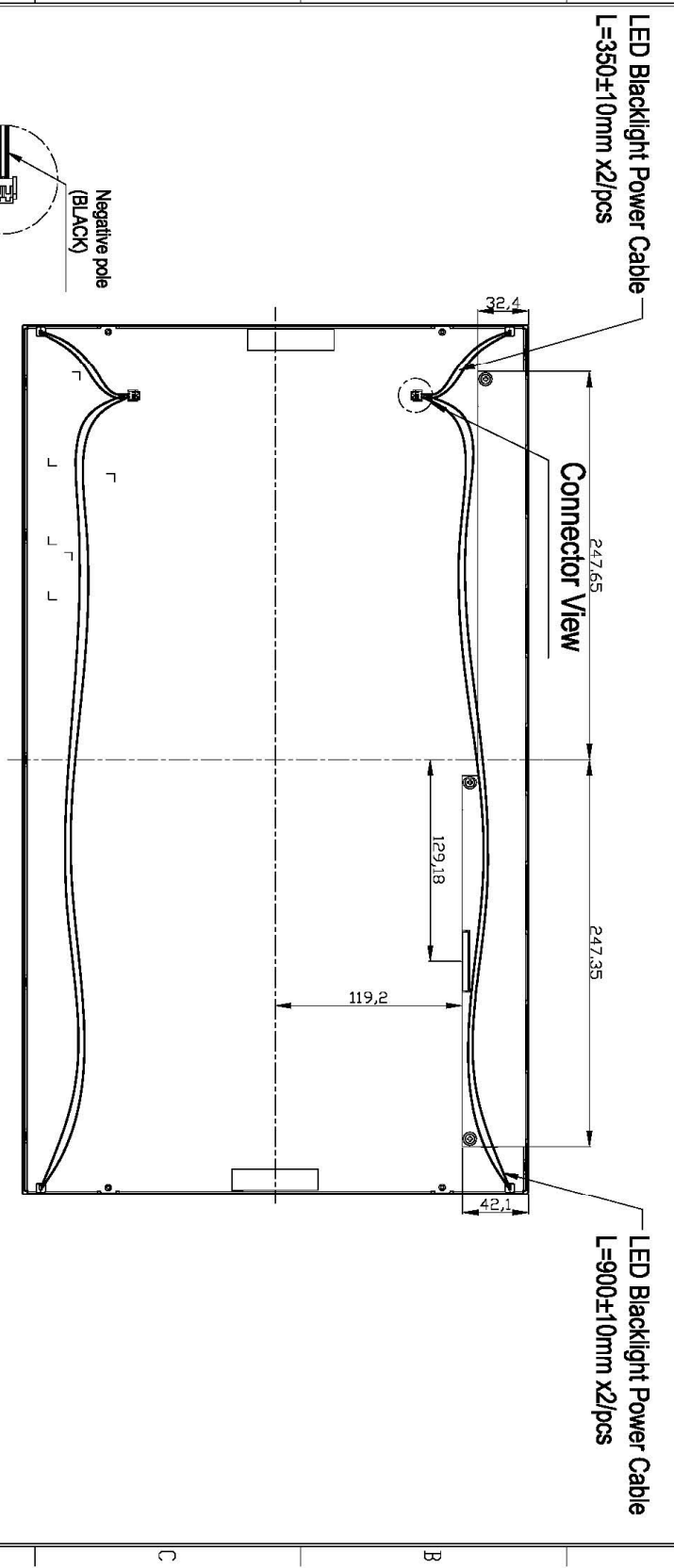

| REV | ECN NO. | DESCRIPTION | STGN | DATE |
|-----|---------|-------------|-------------|------------|
| V0 | - | 正式承認發行 | Penny, Chau | 2010/06/29 |

| APPROVED | CHECKED | DESIGNED | DATE |
|----------|---------|-------------|------------|
| | | Penny, Chau | 2010/06/28 |

| LEVEL | GENERAL TOLERANCE ± | MATERIAL |
|-------|---------------------|----------|
| 0 | ±0.1 | |
| 1 | ±0.15 | |
| 2 | ±0.2 | |
| 3 | ±0.3 | |
| 4 | ±0.5 | |
| 5 | ±1.0 | |
| 6 | ±1.5 | |
| 7 | ±2.0 | |
| 8 | ±3.0 | |
| 9 | ±5.0 | |
| 10 | ±10.0 | |

| DESCRIPTION | REV |
|-------------|-----|
| V0 | |

A4 297x210mm

4.0 TIMING Characteristics

Basically, interface timing described here is not actual input timing of LCD module but close to output timing of SN75LVDS82DGG (Texas Instruments) or equivalent.

| Item | Symbol | Min | Typ | Max | Unit | |
|------------|--------------|----------|------|------|-------|--------|
| Data CLK | Tclk | 40 | 75 | 90 | [MHz] | |
| H-section | Period | Th | 1034 | 1060 | 2047 | [Tclk] |
| | Display Area | Tdisp(h) | 960 | 960 | 960 | [Tclk] |
| | Blanking | Tblk(h) | 74 | 100 | 1087 | [Tclk] |
| V-section | Period | Tv | 1088 | 1120 | 2047 | [Th] |
| | Display Area | Tdisp(v) | 1080 | 1080 | 1080 | [Th] |
| | Blanking | Tblk(v) | 8 | 40 | 967 | [Th] |
| Frame Rate | F | 50 | 60 | 75 | [Hz] | |

Note : DE mode only

Timing diagram

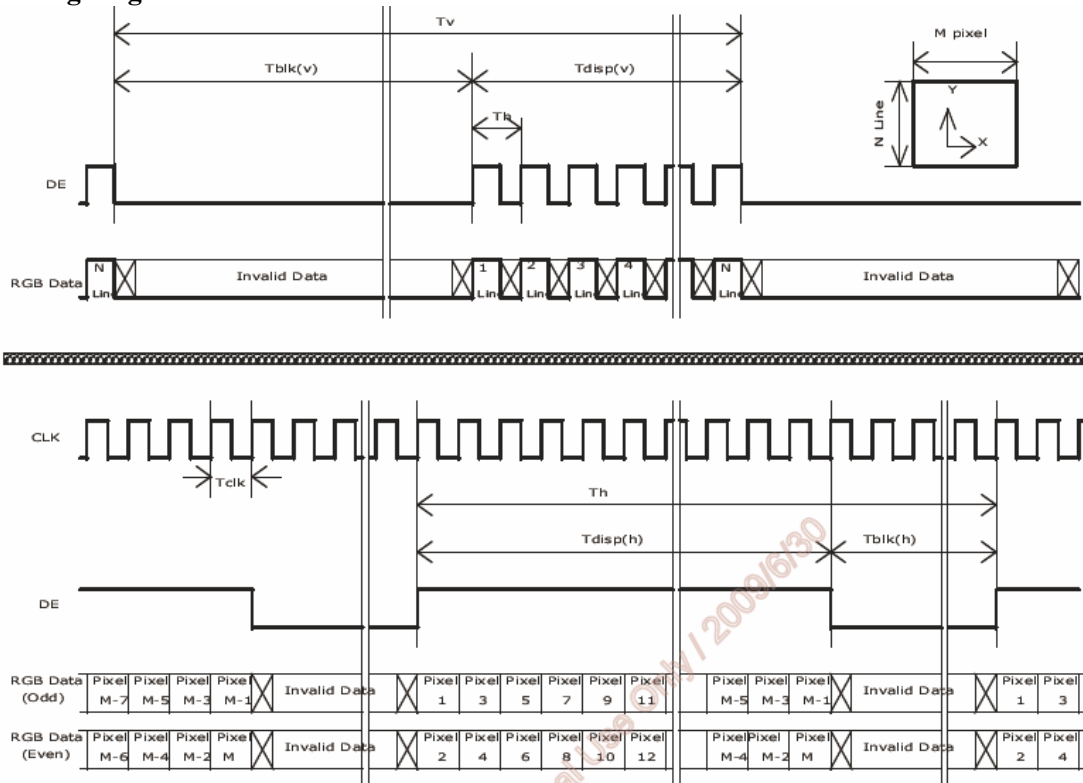

Power ON/OFF Sequence

VDD power and lamp on/off sequence are as follows. Interface signals are also shown in the chart. Signals from any system shall be Hi-Z state or low level when VDD is off.

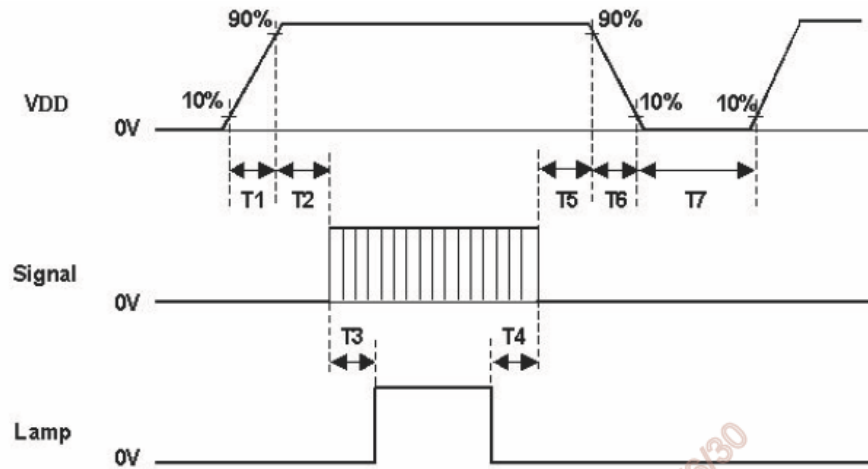

| Parameter | Value | | | Unit |
|-----------|-------|------|------|--------|
| | Min. | Typ. | Max. | |
| T1 | 0.5 | - | 10 | [msec] |
| T2 | 0 | - | 15 | [msec] |
| T3 | 300 | - | - | [msec] |
| T4 | 200 | - | - | [msec] |
| T5 | 0 | 16 | 50 | [msec] |
| T6 | - | - | 100 | [msec] |
| T7 | 1000 | - | - | [msec] |

5.0 CONNECTOR and PIN ASSIGNMENT

TFT LCD Module

| | |
|-------------------------------------|---|
| Connector Name / Designation | Interface Connector / Interface card |
| Manufacturer | JAE Starconn |
| Type Part Number | FI-XB30SRL-HF11 093F30-B0T01A |
| Mating Housing Part Number | FI-X30HL (Locked Type) |

PIN ASSIGNMENT

| Pin# | Signal Name | Pin# | Signal Name |
|------|--|------|--|
| 1 | RxOIN0- | 2 | RxOIN0+ |
| 3 | RxOIN1- | 4 | RxOIN1+ |
| 5 | RxOIN2- | 6 | RxOIN2+ |
| 7 | GND | 8 | RxOCLKIN- |
| 9 | RxOCLKIN+ | 10 | RxOIN3- |
| 11 | RxOIN3+ | 12 | RxEIN0- |
| 13 | RxEIN0+ | 14 | GND |
| 15 | RxEIN1- | 16 | RxEIN1+ |
| 17 | GND | 18 | RxEIN2- |
| 19 | RxEIN2+ | 20 | RxECLKIN- |
| 21 | RxECLKIN+ | 22 | RxEIN3- |
| 23 | RxEIN3+ | 24 | GND |
| 25 | NC (for AUO test only. Do not connect) | 26 | NC (for AUO test only. Do not connect) |
| 27 | VDD | 28 | VDD |
| 29 | VDD | 30 | VDD |

Backlight unit

Connector JST B2B-PH-K-S or compatible

| | |
|------------------------------|----------------------------|
| Connector Name / Designation | Driver Board Connector |
| Manufacturer | ENTERY INDUSTRIAL CO., LTD |
| Mating Type Part Number | 6712K-F10N-02R |

PIN ASSIGNMENT

| Pin no. | Signal name |
|---------|---------------------|
| 1 | IRLED (current out) |
| 2 | IRLED (current out) |
| 3 | IRLED (current out) |
| 4 | IRLED (current out) |
| 5 | VLED (voltage in) |
| 6 | VLED (voltage in) |
| 7 | IRLED (current out) |
| 8 | IRLED (current out) |
| 9 | IRLED (current out) |
| 10 | IRLED (current out) |

6.0 OPTICAL SPECIFICATION

| Item | Unit | Conditions | Min. | Typ. | Max. | Note |
|--|----------------------|--------------------------------------|-------|-------|--------|------|
| Viewing Angle | [degree] | Horizontal (Right) CR = 10 (Left) | 150 | 170 | - - | |
| | | Vertical (Up) CR = 10 (Down) | 140 | 160 | - - | |
| Contrast ratio | | Normal Direction | 600 | 1000 | - | |
| Response Time | [msec] | Raising Time (T_{rR}) | - | 3.5 | 7.4 | |
| | | Falling Time (T_{rF}) | - | 1.5 | 2.6 | |
| | | Raising + Falling | - | 5 | 10 | |
| Color / Chromaticity Coordinates (CIE) | | Red x | 0.608 | 0.638 | 0.668 | |
| | | Red y | 0.318 | 0.348 | 0.378 | |
| | | Green x | 0.304 | 0.334 | 0.364 | |
| | | Green y | 0.578 | 0.608 | 0.638 | |
| | | Blue x | 0.120 | 0.150 | 0.180 | |
| | | Blue y | 0.027 | 0.057 | 0.087 | |
| Color Coordinates (CIE) White | | White x | 0.283 | 0.313 | 0.343 | |
| | | White y | 0.299 | 0.329 | 0.359 | |
| Central Luminance | [cd/m ²] | | 1000 | - | | |
| Luminance Uniformity | [%] | | | - | | |
| Crosstalk (in 60Hz) | [%] | | | 1.5 | | |
| Flicker | dB | | | -20 | | |

7.0 MEASURING METHOD

(1) Definition of Measurement

The LCD module should be stabilized at given temperature for 30 minutes to avoid abrupt temperature change during measuring (at surface 35°C). In order to stabilize the luminance, the measurement should be executed after lighting Backlight for 30 minutes in a stable, windless and dark room.

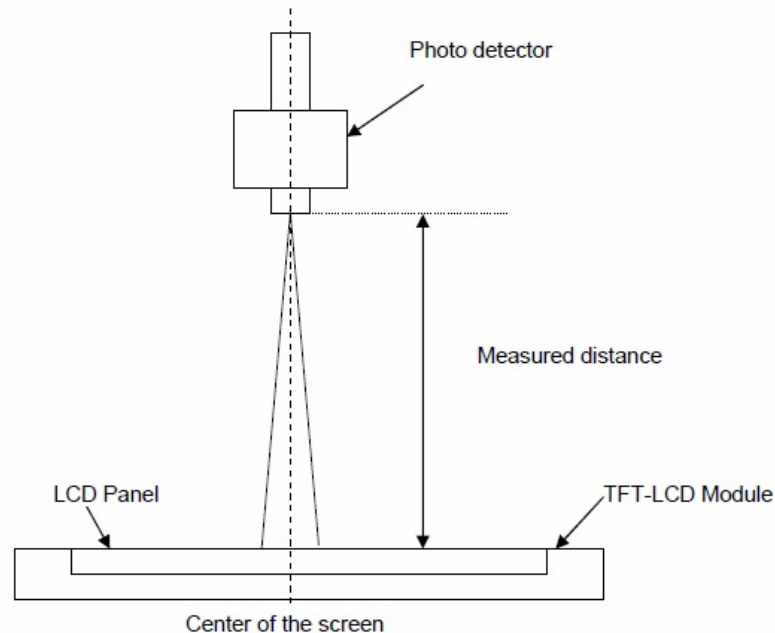

(2) Definition of Viewing Angle :

Viewing angle is the measurement of contrast ratio ≥ 10 , at the screen center, over a 180° horizontal and 180° vertical range (off-normal viewing angles). The 180° viewing angle range is broken down as follows; 90° (θ) horizontal left and right and 90° (Φ) vertical, high (up) and low (down). The measurement direction is typically perpendicular to the display surface with the screen rotated about its center to develop the desired measurement viewing angle.

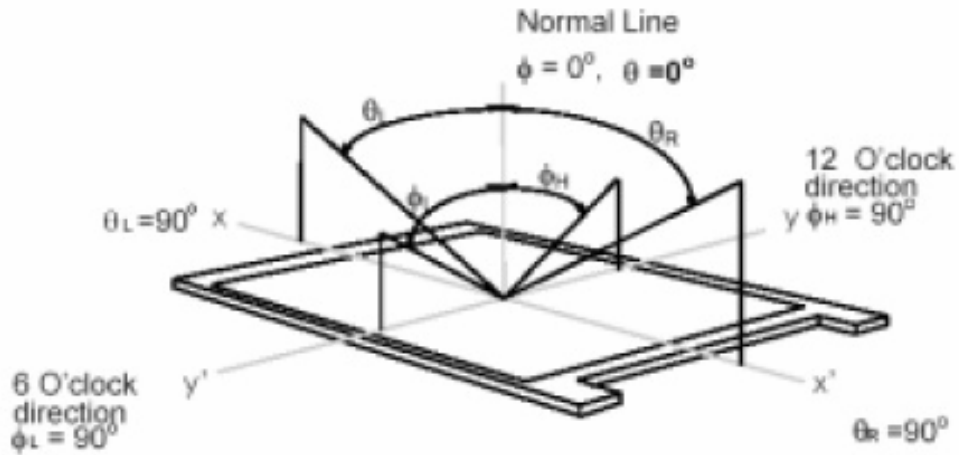

(3) Contrast ratio is measured by TOPCON SR-3

(4) Definition of Response time measured by Westar TRD-100A

The output signals of photo detector are measured when the input signals are changed from “Full Black” to “Full White” (rising time, Tr_R), and from “Full White” to “Full Black” (falling time, Tf_F), respectively. The response time is interval between the 10% and 90% (1 frame at 60 Hz) of amplitudes.

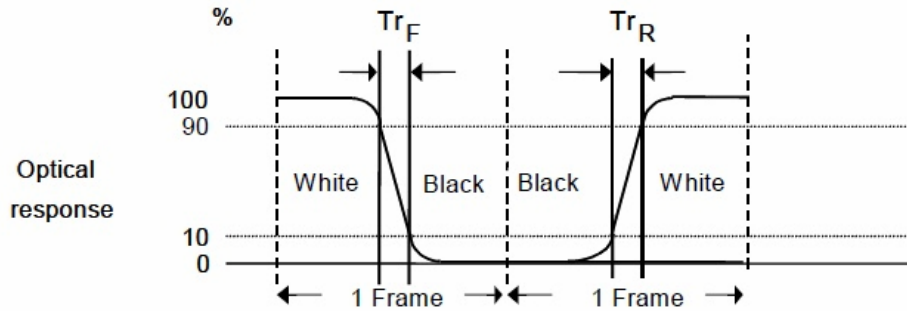

$Tr_R + Tf_F = 5 \text{ msec (typ.)}$.

(5) Color chromaticity and coordinates (CIE) is measured by TOPCON SR-3

(6) Central luminance is measured by TOPCON SR-3

(7) Luminance uniformity of these 9 points is defined as below and measured by TOPCON SR-3

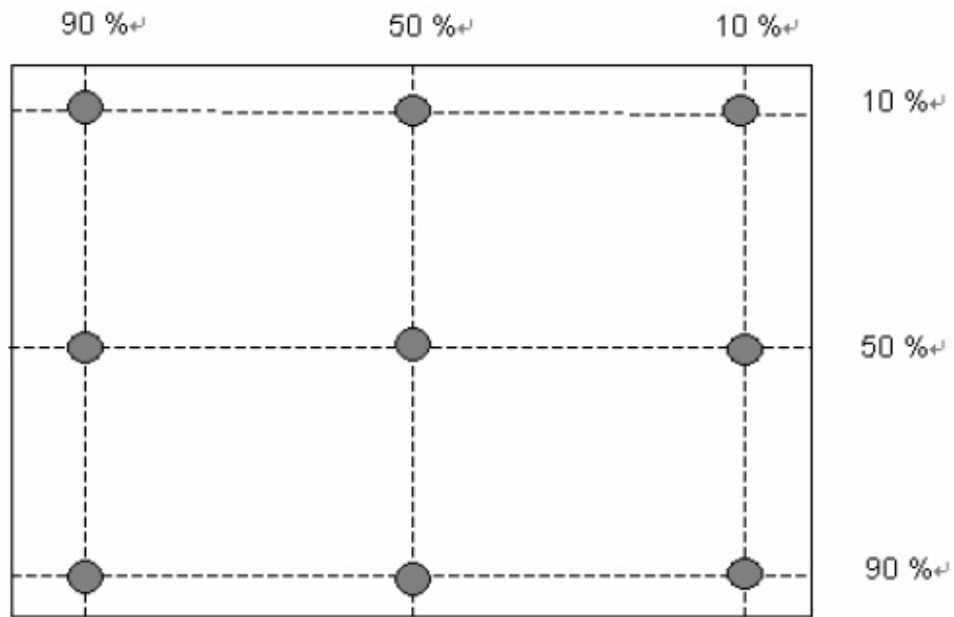

$$\text{Uniformity} = \frac{\text{Minimum Luminance in 9 points (1 - 9)}}{\text{Maximum Luminance in 9 Points (1 - 9)}}$$

(8) Note 8: Crosstalk is defined as below and measured by TOPCON SR-3

$$CT = |YB - YA| / YA \times 100 (\%)$$

Where

YA = Luminance of measured location without gray level 0 pattern (cd/m²)

YB = Luminance of measured location with gray level 0 pattern (cd/m²)

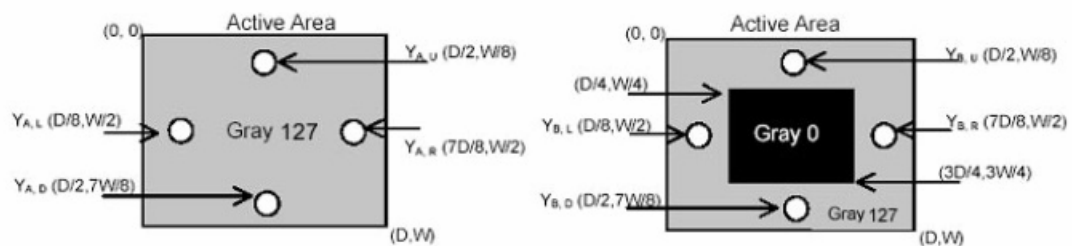

(9) Test Pattern: Subchecker Pattern measured by TOPCON SR-3

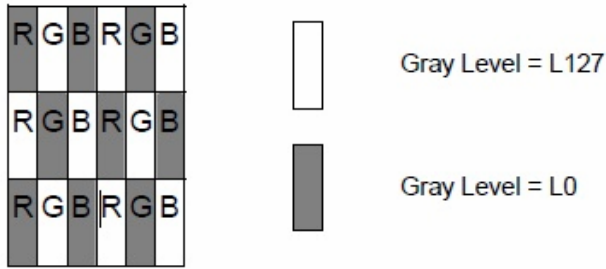

Method: Record dBV & DC value with TRD-100

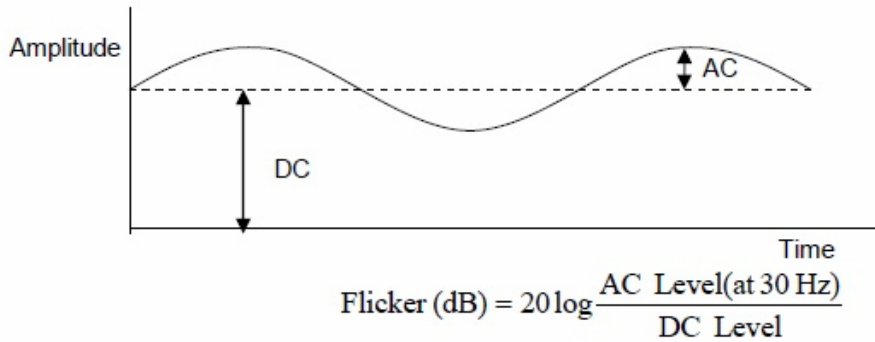

8.0 LED DRIVING BOARD SPECIFICATIONS

1. LED Application

This specification is applied to LED converter unit for DLF/DLH2415 (1000 nits) LED backlight

Specifications:

- Vin=+10V to +14V ±10%
- Constant current and voltage function.
- No load voltage=30V
- LED Light Bar output Voltage=18V(TYPICAL)
- LED Light Bar output current=1.66A @100%(TYPICAL)

- Nominal LED Light Bar working frequency=125KHz ±5KHz
- Nominal PWM frequency=200Hz ±5%
- PWM duty cycle range=0 to 100%
- Average electrical efficiency > 90%

2. Operating Characteristics

| Item | Symbol | Conditions | MIN. | TYP. | MAX. | Unit | Remark |
|---------------------------------|---------|-----------------------|-------|--------|--------|------|--------|
| Input Voltage | Vin | | 10.0 | 12.0 | 14.0 | V | |
| Input Current (Low Brightness) | IinL | VIN=12V,Vadj=5V | 0.0 | ----- | ----- | mA | |
| Input Current (High Brightness) | IinH | VIN=12V,Vadj=0V | 2.826 | 2.671 | 2.33 | A | |
| LED Current (Low Brightness) | IoutL | VIN=12V,Vadj=5V | 0.0 | ----- | ----- | Arms | |
| LED Current (High Brightness) | IoutH | VIN=12V,Vadj=0V | 1.5 | 1.729 | 1.732 | A | |
| Working Frequency | Freq | VIN=12V,Vadj=0V | 120 | 125 | 130 | KHZ | |
| PWM Frequency | Freq | VIN=12V | 180 | 200 | 220 | HZ | |
| Brightness Control | Vadj | Connection of Voltage | 0.5 | ----- | 4.8 | V | |
| ON/OFF Control | Von/off | Normal Operation | 2 | ----- | 5 | V | |
| Output Voltage | Vout | VIN=12V,Vadj=0V | 17.42 | 17.688 | 17.682 | V | |
| Efficiency | η | VIN=12V,Vadj=0V | 91.29 | 95.4 | 93.88 | % | |

Note 1:Efficiency = $[(I_{outH} * V_{out}) / (I_{inH} * V_{in})] * 100\%$, Tolerance $\pm 0.5\%$

3. Connector Socket

3-1. Input Connector: J1 (JST B2B-PH-K-S or Compatible):

| PIN No | Symbol | Description |
|--------|------------|-----------------------------------|
| 1 | Vin | DC+12V |
| 2 | Vin | DC+12V |
| 3 | Vin | DC+12V |
| 4 | GND | Ground |
| 5 | GND | Ground |
| 6 | GND | Ground |
| 7 | Brightness | Brightness Control 5V~0V |
| 8 | Control | ON/OFF Control 0.8V(OFF) 2~5V(ON) |

3-2 . Output Connector : J2, J3(JST S2B-EH or Compatible):

:

| PIN NO | Symbol | Description |
|--------|--------|-----------------------|
| 1 | Output | LED High Voltage(+) |
| 2 | Output | LED Low Voltage (-) |

4. Mechanical Characteristics

Dimension: 124mm*50mm*15mm

INPUT CONNECTOR
 J1:
 PIN1:VIN
 PIN2:VIN
 PIN3:VIN
 PIN4:GND
 PIN5:GND
 PIN6:GND
 PIN7:BRIGHTNESS
 PIN8:ON/OFF

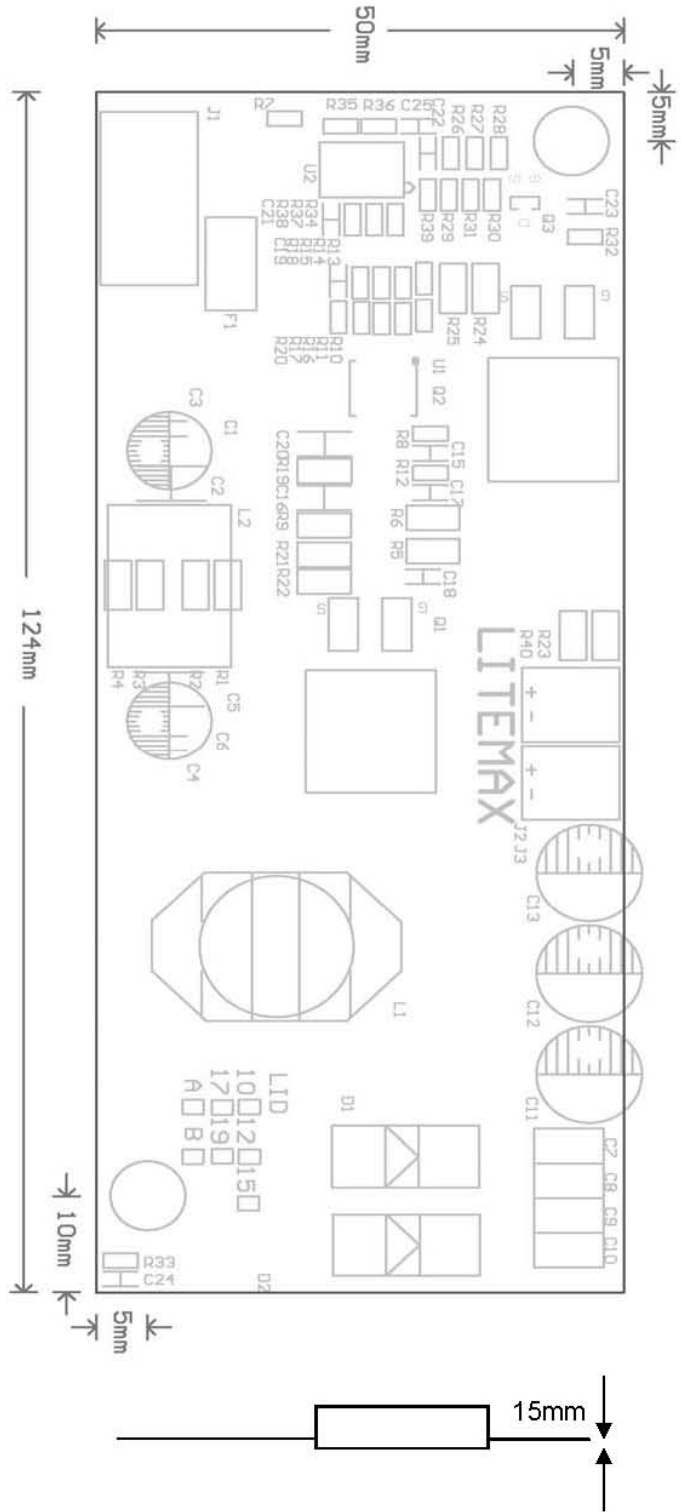

9.0 AD2662GDVAR SPECIFICATIONS(DLH2415 only)

We developed this A/D board to support industrial high brightness and commercial applications. This A/D board has many functions. It has an external luminance sensor as an option, an optional VR button to control brightness, fan rotation and RS232. Rev.1 is European RoHS compliant.

9.1 General Description

- Max Resolution Up To WUXGA
- Analog RGB Input up to 205MHz
- ULTRA-RELIABLE DVI INPUT
- Dual/single LVDS interface
- Support Panel DC5V or 3.3V, 12V Output
- External Fan Control by Software
- OSD Control
- Inverter Analog or PWM Dimming Control
- *External V.R. brightness control (optional)
- *External light sensor brightness control (optional)
- *External RS232 control (optional)
- Input Power 12V DC
- CBVS, S-VIDEO, **YCbCr (optional) INPUT
- Audio in and b2Wx2 Audio Out(optional)
- IR Remote control(optional)

9.2 Outline Dimensions

AD2662GD 150mmX100mmX20mm

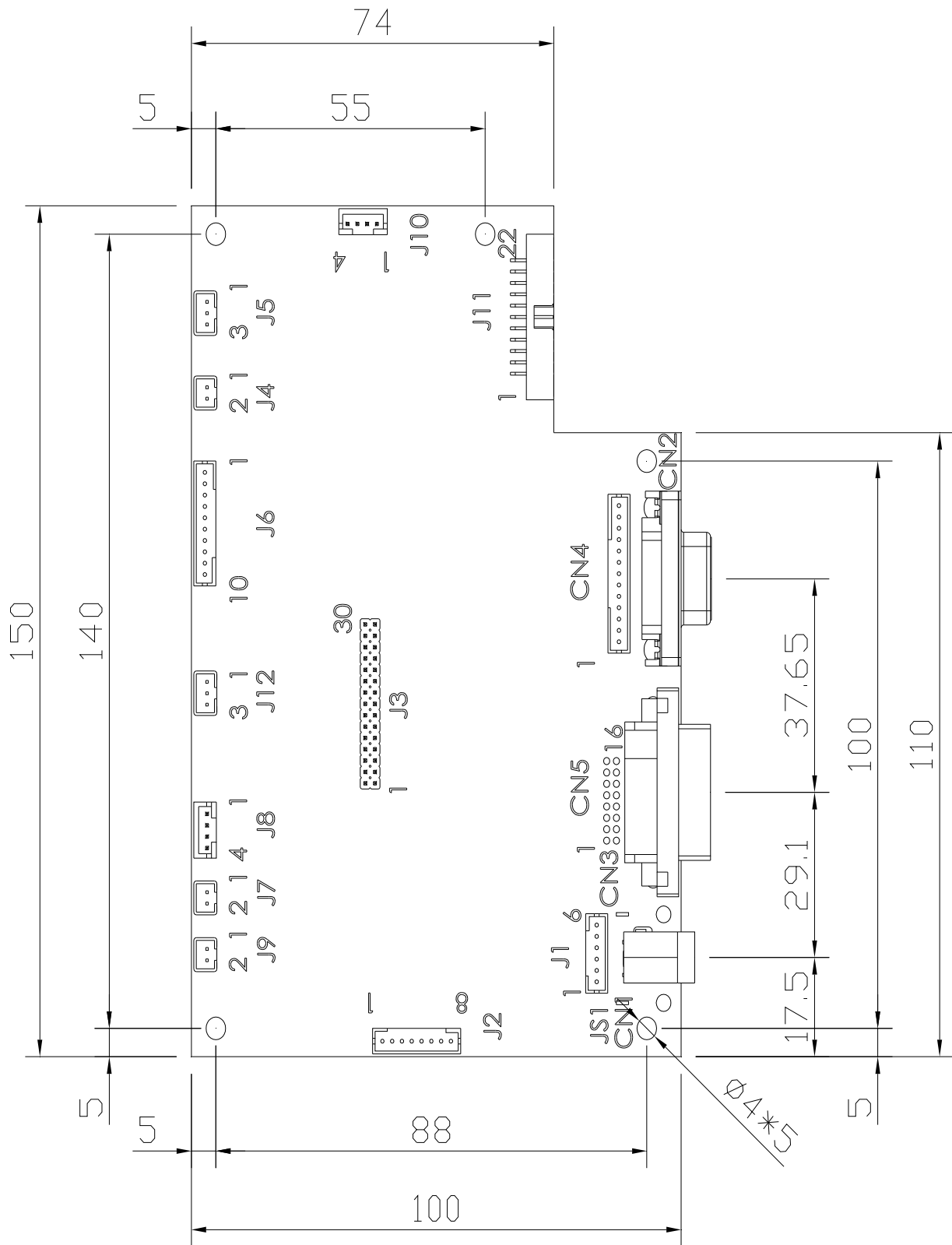

I/O BOARD 160mmX25mmX15mm

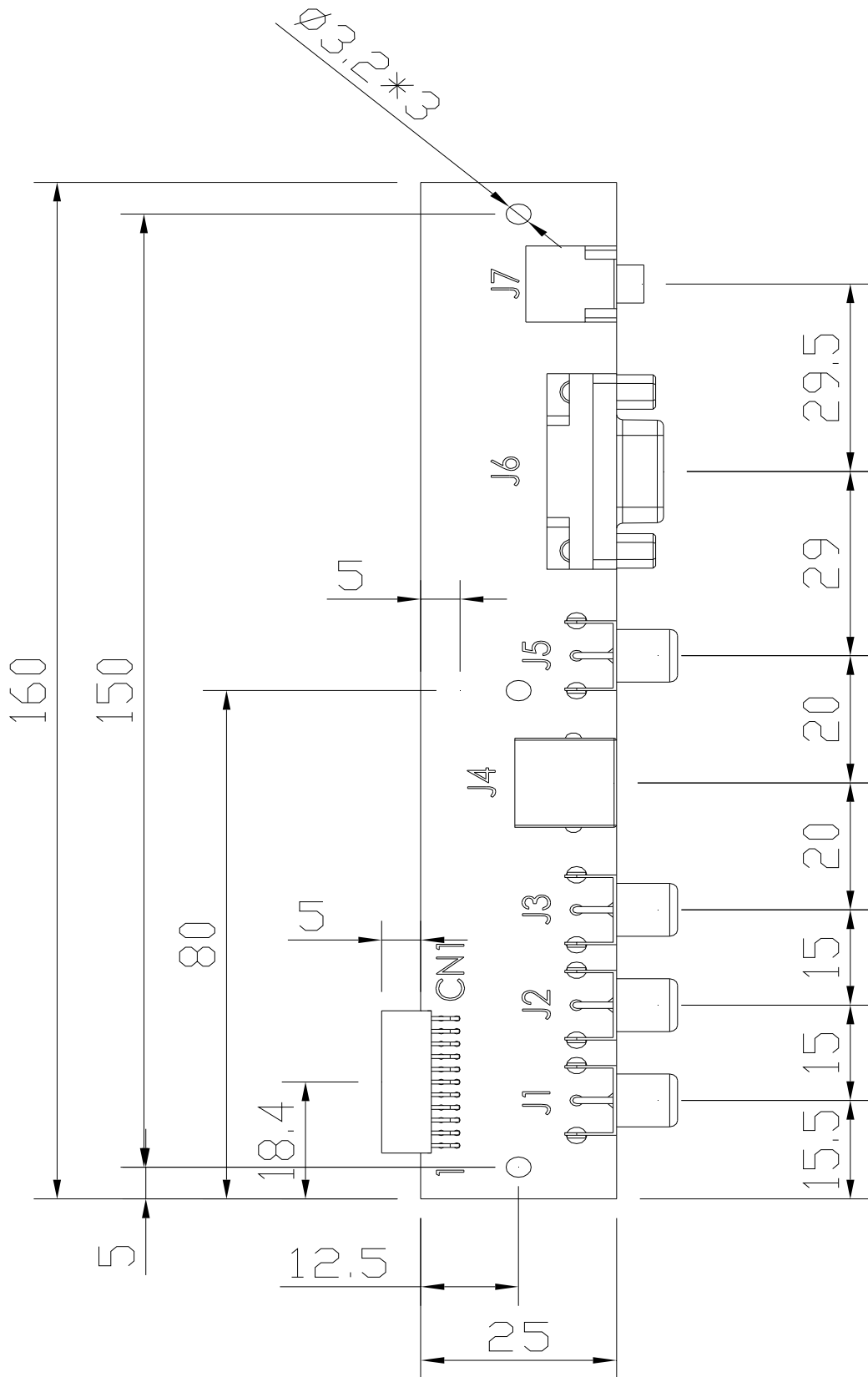

9.3 AD2662 Board Pin Define

J3: Panel connector

| Pin No. | Function | Pin No. | Function |
|---------|----------|---------|-----------|
| 1 | RxO0+ | 16 | RxE1- |
| 2 | RxO0- | 17 | RxE2+ |
| 3 | RxO1+ | 18 | RxE2- |
| 4 | RxO1- | 19 | RxEC+ |
| 5 | RxO2+ | 20 | RxEC- |
| 6 | RxO2- | 24 | RxE3+ |
| 7 | RxOC+ | 22 | RxE3- |
| 8 | RxOC- | 23 | GND |
| 9 | RxO3+ | 24 | GND |
| 10 | RxO3- | 25 | GND |
| 11 | GND | 26 | GND |
| 12 | GND | 27 | GND |
| 13 | RxE0+ | 28 | PANEL-VCC |
| 14 | RxE0- | 29 | PANEL-VCC |
| 15 | RxE1+ | 30 | PANEL-VCC |

CN3: DVI-D INPUT Connector

| Pin No. | Function | Pin No. | Function | Pin No. | Function |
|---------|----------------------------|---------|----------------------------|---------|----------------------------|
| 1 | T.M.D.S. Data2- | 9 | T.M.D.S. Data1- | 17 | T.M.D.S. Data0- |
| 2 | T.M.D.S. Data2+ | 10 | T.M.D.S. Data1+ | 18 | T.M.D.S. Data0+ |
| 3 | T.M.D.S. Data2/4 Shield | 11 | T.M.D.S. Data1/3 Shield | 19 | T.M.D.S. Data0/5 Shield |
| 4 | T.M.D.S. Data4- | 12 | T.M.D.S. Data3- | 20 | T.M.D.S. Data5- |
| 5 | T.M.D.S. Data4+ | 13 | T.M.D.S. Data3+ | 24 | T.M.D.S. Data5+ |
| 6 | DDC Clock | 14 | +5V Power | 22 | T.M.D.S. Clock Shield |
| 7 | DDC Data | 15 | Ground (for +5V) | 23 | T.M.D.S. Clock+ |
| 8 | Not Connected | 16 | Hot Plug Detect | 24 | T.M.D.S. Clock- |

CN5: DVI-D Connector (16pin 2.0mm)

| Pin No. | Function | Pin No. | Function | Pin No. | Function |
|---------|----------|---------|----------|---------|----------|
| 1 | RX2- | 7 | DDC_SDA | 13 | GND |
| 2 | RX2+ | 8 | DDC_SCL | 14 | GND |
| 3 | RX1- | 9 | GND | 15 | DVI HP |
| 4 | RX1+ | 10 | GND | 16 | DVI_5V |
| 5 | RX0- | 11 | RXC- | | |
| 6 | RX0+ | 12 | RXC+ | | |

CN2: Analog RGB Input connector (D-SUB 15Pin)

| Pin No. | Symbol | Description | Pin No. | Symbol | Description |
|---------|-----------|--------------|---------|--------|-----------------|
| 1 | RED | Analog Red | 9 | +5V | +5VDDC |
| 2 | GREEN | Analog Green | 10 | SGND | Sync GND |
| 3 | BLUE | Analog Blue | 11 | NCD | Reserved |
| 4 | GND | Reserved | 12 | SDA | DDC Serial Data |
| 5 | NC | VGA_CAB | 13 | HSYNC | Horizontal Sync |
| 6 | RED_RTN | Red Return | 14 | VSYNC | Vertical Sync |
| 7 | GREEN_RTN | Green Return | 15 | SCL | DDC Data Clock |
| 8 | BLUE_RTN | Blue Return | | | |

CN4: Analog RGB Input connector (13pin connector)

| Pin No. | Symbol | Description | Pin No. | Symbol | Description |
|---------|--------|-----------------|---------|--------|--------------|
| 1 | SCL | DDC Data Clock | 8 | BGND | Blue Return |
| 2 | SDA | DDC Serial Data | 9 | BLUE | Analog Blue |
| 3 | GND | Reserved | 10 | GGND | Green Return |
| 4 | +5V | +5VDDC | 11 | GREEN | Analog Green |
| 5 | GND | Reserved | 12 | RGND | Red Return |
| 6 | VSYNC | Vertical Sync | 13 | RED | Analog Red |
| 7 | HSYNC | Horizontal Sync | | | |

JS1: Power DIN(12V)

| Pin No. | Function | Pin No. | Function |
|---------|----------|---------|----------|
| 1 | 12VDC | 2 | 12VDC |
| 3 | GND | 4 | GND |

JS1: Power Jack (12V)

| Pin No. | Function | Pin No. | Function |
|---------|----------|---------|----------|
| 1 | 12VDC | 2 | 12VDC |

J1: Power connector (12V) (6PIN 2.0mm)

| Pin No. | Function | Pin No. | Function |
|---------|----------|---------|----------|
| 1 | 12VDC | 4 | GND |
| 2 | 12VDC | 5 | GND |
| 3 | 12VDC | 6 | GND |

J8: Power connector (5V/12v)(4PIN 2.0mm)

| Pin No. | Function | Pin No. | Function |
|---------|----------|---------|----------|
| 1 | 5VDC | 2 | GND |
| 3 | 12VDC | 4 | GND |

J2: Inverter Connector(8PIN 2.0mm)

| Pin No. | Symbol | Description | Pin No. | Symbol | Description |
|---------|--------|------------------|---------|--------|-------------|
| 1 | ON/OFF | Backlight ON/OFF | 5 | GND | GND |
| 2 | BRIGHT | Dimming adjust | 6 | 12VDC | Input 12VDC |
| 3 | GND | GND | 7 | 12VDC | Input 12VDC |
| 4 | GND | GND | 8 | 12VDC | Input 12VDC |

J7, J9: FAN (2PIN 2.0mm)

| Pin No. | Function | Pin No. | Function |
|---------|----------|---------|----------|
| 1 | FAN(+) | 2 | GND |

J6: Key Pad (9PIN 2.0mm)

| Pin No. | Function | Pin No. | Function |
|---------|-----------|---------|----------|
| 1 | POWER KEY | 6 | MENU KEY |
| 2 | GREEN LED | 7 | AUTO KEY |
| 3 | RED LED | 8 | GND |
| 4 | DOWN KEY | 9 | GND |
| 5 | UP KEY | | |

J10: Speaker Connector (4PIN 2.0mm)

| Pin No. | Function | Pin No. | Function |
|---------|----------|---------|----------|
| 1 | SPK-R | 2 | GND |
| 3 | GND | 4 | SPK-L |

J11 Extern Funtion Connector (11P X 2PIN 2.0mm)

| Pin No. | Function | Pin No. | Function |
|---------|----------|---------|----------|
| 1 | Pb | 2 | Y |
| 3 | GND | 4 | Pr |
| 5 | GND | 6 | SY |
| 7 | GND | 8 | SC |
| 9 | GND | 10 | AV |
| 11 | GND | 12 | GND |
| 13 | TXD | 14 | RXD |
| 15 | GND | 16 | GND |
| 17 | GND | 18 | GND |
| 19 | Audio-L | 20 | Audio-R |
| 24 | GND | 22 | GND |

J5: Ambient (3PIN 2.0mm)

| Pin No. | Function | Pin No. | Function |
|---------|----------|---------|------------|
| 1 | 3.3VDC | 2 | Sensor Out |

J4: VR connector (3PIN 2.0mm)

| Pin No. | Function | Pin No. | Function |
|---------|----------|---------|----------|
| 1 | 3,3VDC | 2 | VR Out |
| 3 | GND | | |

J12: IR Connector(3PIN 2.0mm)

| Pin No. | Function | Pin No. | Function |
|---------|----------|---------|----------|
| 1 | IR Out | 3 | 3.3VDC |
| 2 | GND | 4 | |

JP1: PANEL VCC (3PIN 2.54mm)

| Pin No. | Function | Pin No. | Function |
|---------|----------|---------|----------|
| 1-2 | 12V | 5-6 | 3.3V |
| 3-4 | 5V | | |

9.4 I/O BOARD Pin Define

J1:Component Y

| Pin No. | Function | Pin No. | Function |
|---------|----------|---------|----------|
| 1 | Y | 2 | GND |

J2:Component Cb

| Pin No. | Function | Pin No. | Function |
|---------|----------|---------|----------|
| 1 | Cb | 2 | GND |

J3:Component Cr

| Pin No. | Function | Pin No. | Function |
|---------|----------|---------|----------|
| 1 | Cr | 2 | GND |

J4:S-Video

| Pin No. | Function | Pin No. | Function |
|---------|-----------|---------|-------------|
| 1 | GND | 2 | GND |
| 3 | Luminance | 4 | Chrominance |

J5:Composite

| Pin No. | Function | Pin No. | Function |
|---------|----------|---------|----------|
| 1 | Y | 2 | GND |

J6:D-SUB9(RS232)

| Pin No. | Function | Pin No. | Function |
|---------|----------|---------|----------|
| 1 | NC | 2 | TXD |
| 3 | RXD | 4 | NC |
| 5 | GND | 6 | NC |
| 7 | NC | 8 | NC |
| 9 | NC | | |

CN1:11P X 2 Connector

| Pin No. | Function | Pin No. | Function |
|---------|--------------|---------|--------------|
| 1 | Component Cb | 2 | Component Y |
| 3 | GND | 4 | Component Cr |
| 5 | GND | 6 | S-Video Y |
| 7 | GND | 8 | S-Video C |
| 9 | GND | 10 | Composite |
| 11 | GND | 12 | GND |
| 13 | TXD | 14 | RXD |
| 15 | GND | 16 | GND |
| 17 | GND | 18 | GND |
| 19 | Audio IN(L) | 20 | Audio IN(R) |

9.5 IR Receive Board Pin Define

J1: IR Connector

| Pin No. | Function | Pin No. | Function |
|---------|----------|---------|----------|
| 1 | DATA OUT | 2 | GND |
| 3 | VCC | 4 | NC |

9.6 DC Characteristics.

| | | |
|-----------------------|--------|-------|
| Power Consumption | 10W | Note1 |
| Operation Temperature | 0~70 | °C |
| Storage Temperature | -20~85 | °C |

Note: These values are for the A/D board body.

9.7 OSD menu

Here are some instructions for you to use the OSD (On Screen Display). By pressing the “menu”, you will see the below picture.

Timing shows resolution, H-frequency, and V-frequency of the panel. Version shows the firmware control version. This 2 information is not changeable by user.



There are 7 sub pages inside the OSD manual, Brightness, Signal select, Sound, Color, Image, Tools, and Exit.

When you press “menu” button, you enter the “Brightness” sub page. You will see 5 selections:



press “menu”



press “menu”



press “menu”



OSD Brightness:



press “right” key



press “menu” once, you can go into adjust the brightness. Press “left” you can dim down the brightness to “0”, while press “right” you can increase the brightness to “100”.



Ambient light sensor: press this Icon, must to accompany with Litemax ambient light sensor to auto dimming.(OPTION)



Potentiometer: press this icon, adjust VR function.(OPTION)



Ambient light sensor with OSD offset: press this Icon



Press ‘menu’ once, you can adjust min. luminance to fit your application (OPTION)



Contrast: Press “menu” and “right” you can adjust the contrast from “0” to “100” by pressing the “left” and “right”.



Exit: You can exit this sub menu back to normal screen.

Sound :

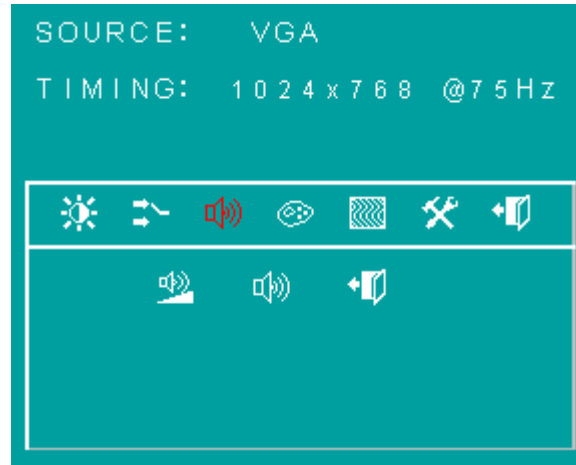

There are 3 options for “Sound” sub page.



Audio Volume: Audio volume adjustment.



Mute: You can mute the speaker by pressing this option.



Exit: back to the normal screen.



Auto Color: by press this “Auto Color” option, you can get the optimal color performance.



sRGB: Windows standard color setting.



Color Tempture: You can have 3 options in this selection.



Color Tempture User



Color Tempture_6500K



Color Tempture_9300K

“user mode”, “6500K” (Warm color scheme), “9300K (Cold color scheme).
Default is “user”, and inside all “R”, “G”, and “B” are set “100”



Exit: back to the normal screen.

Image :

Go into the “Image” page, you can see below picture.

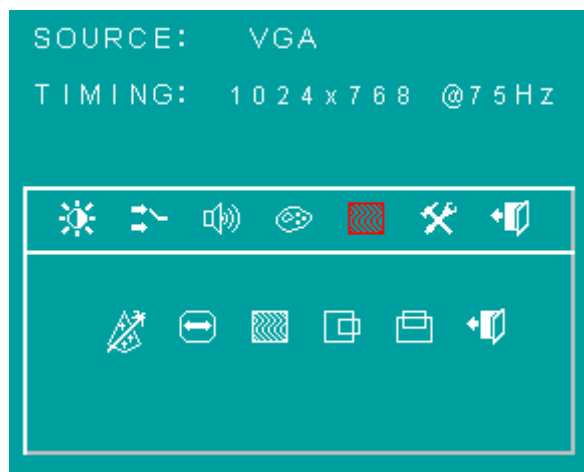



Auto just: Pressing this option, the AD2662 will adjust the optimal frequency of horizontal and vertical. You will see “Auto tune....” On the screen for around 3 seconds.



Clock: If you are not satisfied about the Autotune result, you can adjust manually by “Clock”. The screen will be “wider” if you adjust this function.



Phase: If you see “double image” on characters, you can adjust “Phase” to make it perfect image.



HPos: You can shift the screen horizontally by this function.



Vpos: You can shift the screen vertically by this function.



Exit: Back to normal screen.

TOOLS :

On the “Tools” sub menu, you will see 4 icons.



Osd Control: Select this option, you will see 4 more options:





Osd_time: You can selection the time of OSD from 2 sec. to 16 sec.



Osd_HPos: You can move the OSD horizontally over the screen.



Osd_VPos: You can move the OSD Vertically over the screen.



Exit: back to main menu.



Factory_Reset: By pressing this, the screen will be back to the factory setting on very beginning and lost all the personal settings.



Sharpness: You can make the characters looks sharper.



Exit

BURNIN MODE :

Factory Burn-in mode: While your VGA cable is connected on the monitor, press “Menu” and Left and Right <” simultaneously, you will see “BURN IN MODE” on the center of the screen for 3 sec. Then unplug the VGA cable, the screen will show Red, Green, Blue, White, and Black in sequence automatically.

You can plug in the VGA signal cable, and re-plug the power connector to exit the burn-in mode.

KEY LOCK MODE :

OSD Lock Function: It is possible to lock all the OSD buttons to prevent unauthorized changes to occur by pressing “Menu” and “right >” buttons simultaneously. You will see the “lock” icon below on the center of the screen for 3 seconds. If any button is pushed after the lock function is initiated, the below icon will appear on the screen.'



To release the OSD lock, press “Menu” and “Right >”. The below icon will appear on the center of the screen for 3 seconds. Now all OSD keys are active again.

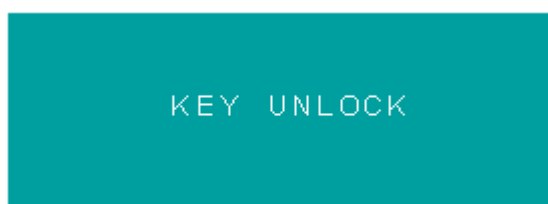

10.0 MECHANICAL DRAWING

DLF/DLH2415

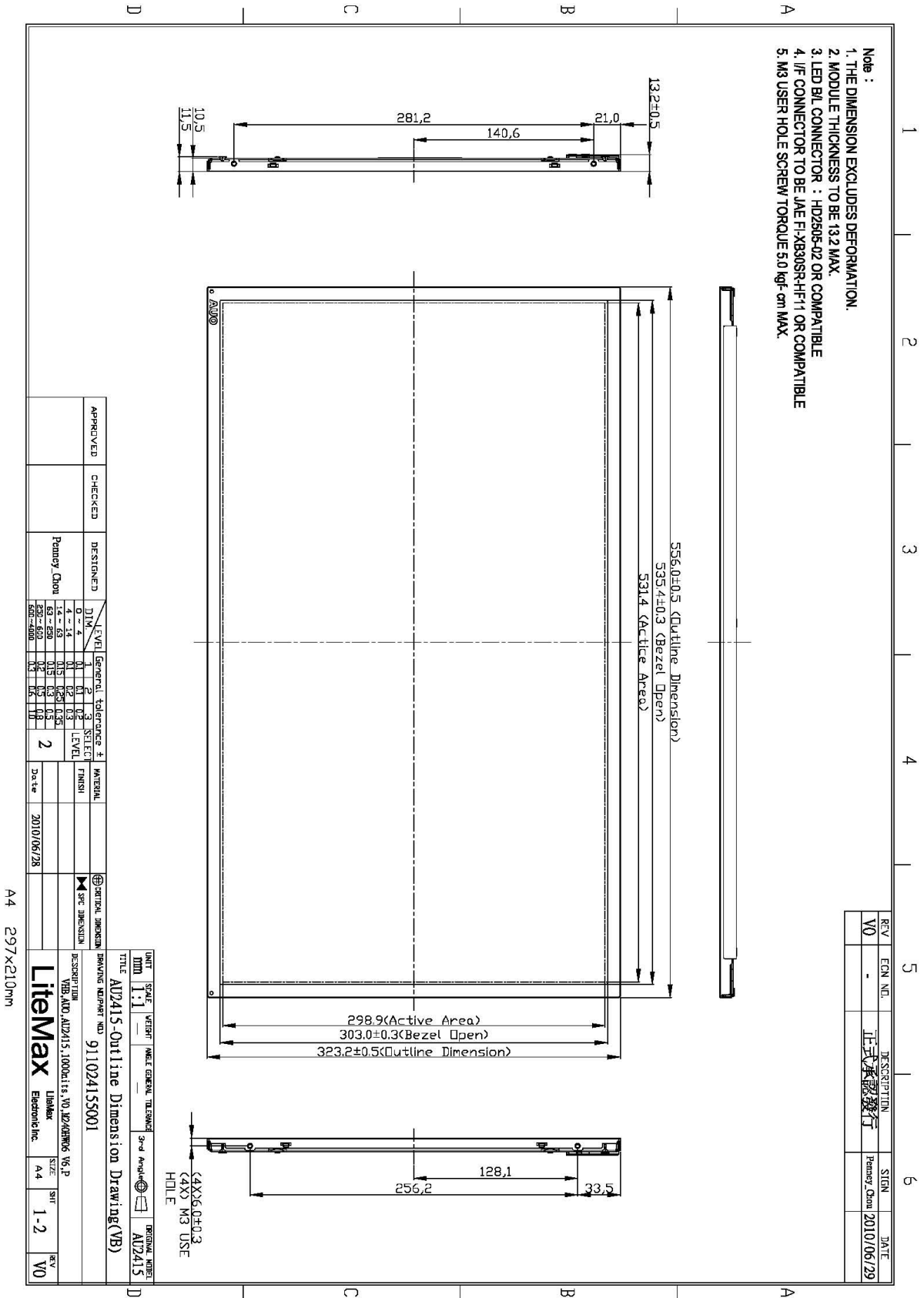

- Note :
1. THE DIMENSION EXCLUDES DEFORMATION.
 2. MODULE THICKNESS TO BE 13.2 MAX.
 3. LED B/L CONNECTOR : HD2905-02 OR COMPATIBLE
 4. I/F CONNECTOR TO BE JAE FI-XB39SR-H/F11 OR COMPATIBLE
 5. M3 USER HOLE SCREW TORQUE 5.0 kgf·cm MAX.

| REV | ECN NO. | DESCRIPTION | DATE |
|-----|---------|--------------|------------|
| V0 | - | 正式承認發行 | 2010/06/29 |
| | | Penney, Dion | |

| APPROVED | CHECKED | DESIGNED | DATE |
|----------|---------|--------------|------------|
| | | Penney, Dion | 2010/06/28 |

A4 297x210mm

| | | | | | | | |
|--|-------|----------|-------|---------|----------|-----------|---------------|
| UNIT | SCALE | VERTICAL | INLET | GENERAL | TELEGRAM | 3rd Angle | ORIGINAL NAME |
| mm | 1:1 | | | | | | AU2415 |
| TITLE AU2415-Outline Dimension Drawing(VB) | | | | | | | |
| DESCRIPTION VB8 A10, AU2415, 1.000Dx16, V0, J24/WH06 V6, P | | | | | | | |
| DRAWING NUMBER NO 911024155001 | | | | | | | |
| LienMax Libmax SIZE: A4 SH: 1-2 REV: V0 | | | | | | | |
| Electronic Inc. | | | | | | | |

1 2 3 4 5 6

- Note :
1. THE DIMENSION EXCLUDES DEFORMATION.
 2. MODULE THICKNESS TO BE 13.2 MAX.
 3. LED B/L CONNECTOR : HD2505-02 OR COMPATIBLE
 4. I/F CONNECTOR TO BE JAE FI-XB30SR-HF11 OR COMPATIBLE
 5. M3 USER HOLE SCREW TORQUE 5.0 kgf·cm MAX.

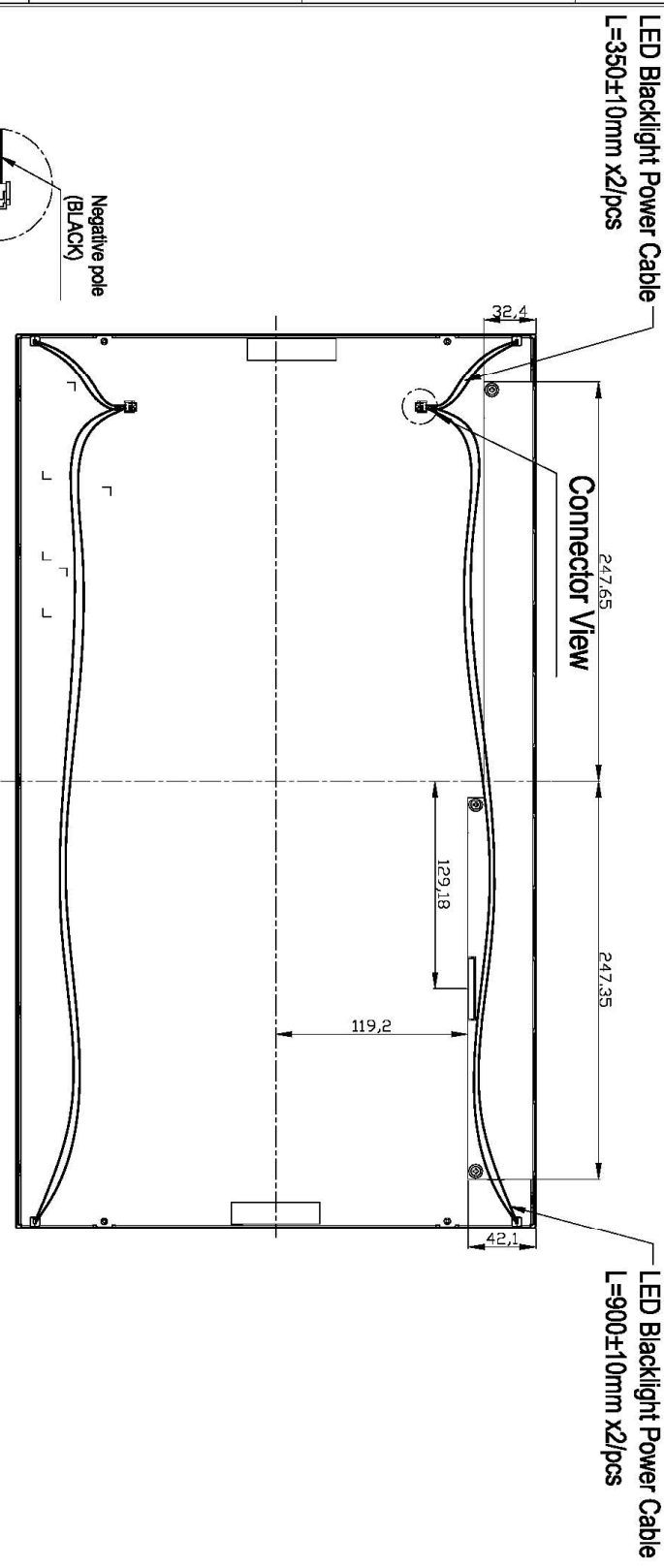

Connector View

| APPROVED | CHECKED | DESIGNED | DATE |
|----------|---------|--------------|------------|
| | | Penney, Dion | 2010/06/28 |

| LEVEL | GENERAL TOLERANCES | FINISH |
|----------|--------------------|--------|
| 0 - 4 | M1, M2, M3 | |
| 4 - 14 | M1, M2, M3 | |
| 14 - 25 | M1, M2, M3 | |
| 25 - 50 | M1, M2, M3 | |
| 50 - 100 | M1, M2, M3 | |

| DATE | SCALE | VERTICAL | INCL. GENERAL TOLERANCE | 3rd Angle | ORIGINAL NAME |
|------------|-------|----------|-------------------------|-----------|---------------|
| 2010/06/28 | 1:1 | | | | AU2415 |

A4 297x210mm

| REV | ECN NO. | DESCRIPTION | SIGN | DATE |
|-----|---------|-------------|--------------|------------|
| V0 | - | 正式承認發行 | Penney, Dion | 2010/06/29 |

11.0 PRECAUTIONS

HANDLING PRECAUTIONS

- (1) The module should be assembled into the system firmly by using every mounting hole. Be careful not to twist or bend the module.
- (2) While assembling or installing modules, it can only be in the clean area. The dust and oil may cause electrical short or damage the polarizer.
- (3) Use fingerstalls or soft gloves in order to keep display clean during the incoming inspection and assembly process.
- (4) Do not press or scratch the surface harder than a HB pencil lead on the panel because the polarizer is very soft and easily scratched.
- (5) If the surface of the polarizer is dirty, please clean it by some absorbent cotton or soft cloth. Do not use Ketone type materials (ex. Acetone), Ethyl alcohol, Toluene, Ethyl acid or Methyl chloride. It might permanently damage the polarizer due to chemical reaction.
- (6) Wipe off water droplets or oil immediately. Staining and discoloration may occur if they left on panel for a long time.
- (7) If the liquid crystal material leaks from the panel, it should be kept away from the eyes or mouth. In case of contacting with hands, legs or clothes, it must be washed away thoroughly with soap.
- (8) Protect the module from static electricity, it may cause damage to the C-MOS Gate Array IC.
- (9) Do not disassemble the module.
- (10) Do not pull or fold the lamp wire.
- (11) Pins of I/F connector should not be touched directly with bare hands.

STORAGE PRECAUTIONS

- (1) High temperature or humidity may reduce the performance of module. Please store LCD module within the specified storage conditions.
- (2) It is dangerous that moisture come into or contacted the LCD module, because the moisture may damage LCD module when it is operating.
- (3) It may reduce the display quality if the ambient temperature is lower than 10 °C. For example, the response time will become slowly, and the starting voltage of lamp will be higher than the room temperature.

OPERATION PRECAUTIONS

- (1) Do not pull the I/F connector in or out while the module is operating.
- (2) Always follow the correct power on/off sequence when LCD module is connecting and operating. This can prevent the CMOS LSI chips from damage during latch-up.