



LITEMAX DLF/DLH1555

Sunlight readable 15" LED B/L LCD

(2st Edition 8/14/2007)

All information is subject to change without notice.

Approved by	Checked by	Prepared by
David	Sharline	River, Eric

LITEMAX Electronics Inc.

8F, No.137, Lane 235, Bau-chiau Rd.,
Shin-dian City, Taipei County, Taiwan R.O.C.

Tel : 886-2-8919-1858

Fax: 886-2-8919-1300

Homepage: <http://www.litemax.com.tw>

Record of Revision

Version and Date	Page	Old Description	New Description	Remark
8/14/07" v.01			First Release	
8/11/08" v2.1	7	LED Voltage 17V	LED Voltage 17.15V	Revision
		LED Current 1350mA	LED Current 872mA	
	9	Power Consumption 24.3W	Power Consumption 14.95W	
	11	Backlight Connector Part:	Connector Part: HD2505-02 or equivalent	Add
		TBD	Matching Connector Part No.:TD2505-02or equivalent	
	15	TEST CONDITIONS		Revision
		LED Current 1350mA LED Driver Board : Litemax LID15A01	LED Current 872mA LED Driver Board : Litemax LID15A02	
		OPTICAL SPECIFICATIONS		
		Color chromaticity : Rx=0.613 Ry=0.334 Gx=0.302 Gy=0.567 Bx=0.144 By=0.102 Wx=0.313 Wy=0.329	Rx=0.603 Ry=0.371 Gx=0.375 Gy=0.541 Bx=0.165 By=0.084 Wx=0.341 Wy=0.329	

Contents

Record of Revision	2
Contents	3
GENERAL DESCRIPTION	4
OVERVIEW	4
FEATURES	4
APPLICATION	4
GENERAL SPECIFICATIONS	4
MECHANICAL SPECIFICATIONS	5
ABSOLUTE MAXIMUM RATINGS	6
ABSOLUTE RATINGS OF ENVIRONMENT	6
ELECTRICAL ABSOLUTE RATINGS	6
ELECTRICAL CHARACTERISTICS	8
TFT LCD MODULE	8
BACKLIGHT UNIT	9
BLOCK DIAGRAM	10
TFT LCD MODULE	10
INPUT TERMINAL PIN ASSIGNMENT	11
TFT LCD MODULE	11
BACKLIGHT UNIT	11
COLOR DATA INPUT ASSIGNMENT	12
INTERFACE TIMING	13
INPUT SIGNAL TIMING SPECIFICATIONS	13
POWER ON/OFF SEQUENCE	14
OPTICAL CHARACTERISTICS	15
TEST CONDITIONS	15
OPTICAL SPECIFICATIONS	15
PRECAUTIONS	19
HANDLING PRECAUTIONS	19
STORAGE PRECAUTIONS	19
OPERATION PRECAUTIONS	19

GENERAL DESCRIPTION

OVERVIEW

CM1555E is a 15.0" TFT Liquid Crystal Display module with LED Backlight units and 20 pins LVDS interface. This module supports 1024 x 768 XGA mode and can display 16.2M colors. The PSWG is to establish a set of displays with standard mechanical dimensions and select electrical interface requirements for an industry standard 15.0" XGA LCD panel and the inverter module for Backlight is not built in.

FEATURES

- LED B/L
- 1000 nits
- Wide dimming range
- XGA (1024 x 768 pixels) resolution
- DE(data enable) only mode
- LVDS interface with 1pixel/clock
- PSWG (panel standardization working group)
- Wide operating temperature.
- RoHs compliance

APPLICATION

- TFT LCD monitor
- Factory application
- Amusement
- Transportation

GENERAL SPECIFICATIONS

Item	Specification	Unit	Note
Active Area	304.128 (H) x 228.096(V) (15.0"LED Backlight)	mm	(1)
Bezel Opening Area	307.4(H) x 231.3(V)	mm	
Driver Element	a-Si TFT active matrix	-	-
Pixel Number	1024 x R.G.B x 768	pixel	-
Pixel Pitch	0.297(H) x 0.297(W)	mm	-
Pixel Arrangement	RGB vertical stripe	-	-
Display Colors	16.2M color	color	-
Display Mode	Normally white	-	-
Surface Treatment	Hard Coating (3H), Anti-Glare (Haze 25)	-	-

MECHANICAL SPECIFICATIONS

Item		Min.	Typ.	Max.	Unit	Note
Module Size	Horizontal(H)	326.0	326.5	327.0	mm	(1)
	Vertical(V)	253.0	253.5	254.0	mm	
	Depth(D)	-	-	14.5	mm	(1)(2)
Weight		-	-	1200	g	-

Note (1) Please refer to the attached drawings for more information of front and back outline dimensions. Note

(2) The depth is without connector.

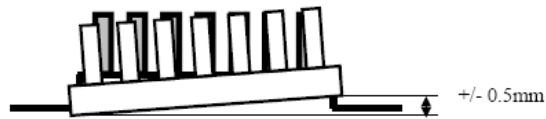

ABSOLUTE MAXIMUM RATINGS

ABSOLUTE RATINGS OF ENVIRONMENT

Item	Symbol	Value		Unit	Note
		Min.	Max.		
Storage Temperature	T _{ST}	-40	80	°C	(1)
Operating Ambient Temperature	T _{OP}	-20	60	°C	(1), (2), (6)
Shock (Non-Operating)	S _{NOP}	-	50G	G	(3), (5)
Vibration (Non-Operating)	V _{NOP}	-	1.5	G	(4), (5)

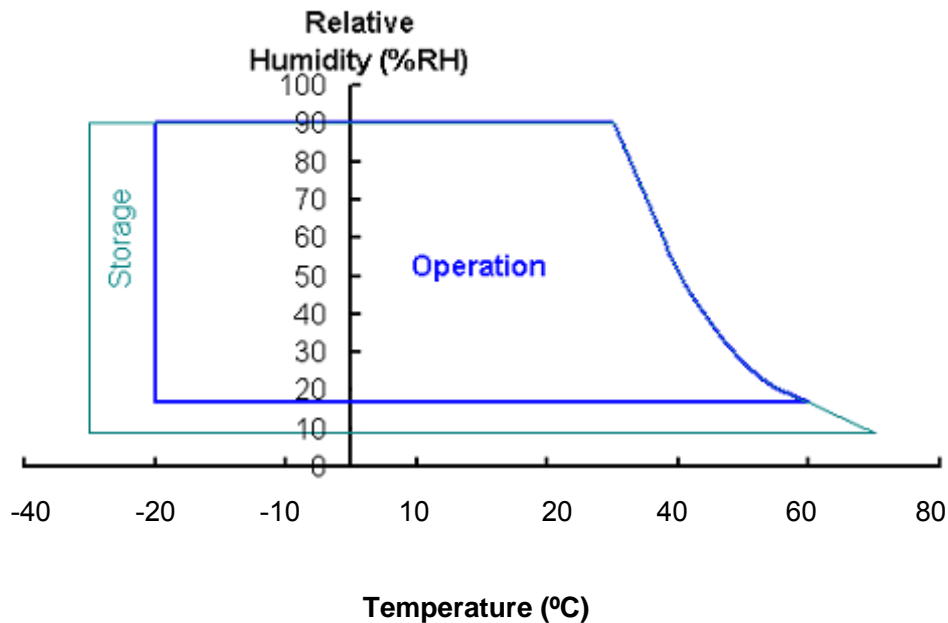

Note (1) Temperature and relative humidity range is shown in the figure below.

(a) 90 %RH Max. ($T_a \leq 40$ °C).

(b) No condensation of water.

Note (2) The temperature of panel surface should be -20°C Min. and 60 °C Max.

Note (3) 11ms, 1 time each $\pm X, \pm Y$ and $\pm Z$ directions

Note (4) 10 ~ 500 Hz sine wave, 30 min./1 cycle , 1.5mm max, 30 min. each X, Y and Z directions

Note (5) At testing Vibration and Shock, the fixture in holding the module has to be hard and rigid enough so that the module would not be twisted or bent by the fixture.

Note (6) Panel at -20°C ~ 60 °C operating ambient temperature should guarantee function work.

ELECTRICAL ABSOLUTE RATINGS

TFT LCD MODULE

Item	Symbol	Value		Unit	Note
		Min.	Max.		
Power Supply Voltage	V _{DD}	-0.3	4.0	V	

BACKLIGHT UNIT

Item	Symbol	Value			Unit	Note
		Min.	Type.	Max		
LED Voltage	V _L	-	17.15	-	V _{RMS}	
LED Current	I _L	828.4	872	915.6	mA _{RMS}	
LED Working Frequency	F _L	120	125	130	KHz	

ELECTRICAL CHARACTERISTICS

TFT LCD MODULE

Parameter	Symbol	Value			Unit	Note	
		Min	Type	Max			
Power Supply Voltage	V_{DD}	3.0	3.3	3.6	V	-	
Ripple Voltage	V_{RP}	-	-	100	mVp-p		
Rush Current	I_{RUSH}	-	-	2.0	A	(2)	
Power Supply Current	White	I_{CC}	-	500	mA	(3)a	
	Black		-	750			
Differential Input Voltage for LVDS Receiver Threshold	"H" Level	V_{IH}	-	-	100	mV	-
	"L" Level	V_{IL}	-100	-	-	mV	-
Terminating Resistor	R_T		100	-	Ohm	-	

Note (1) The module should be always operated within above ranges.

Note (2) Measurement Conditions:

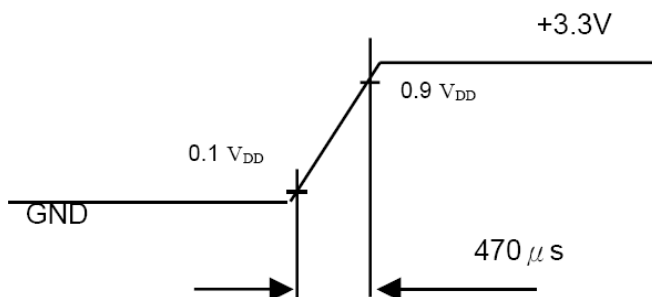
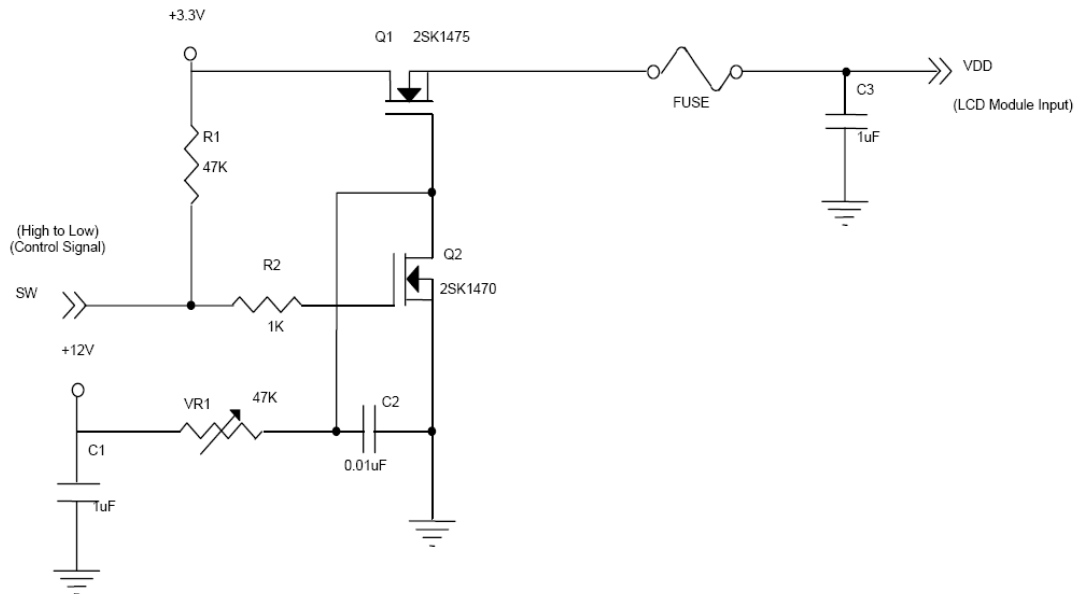

Note (3) The specified power supply current is under the conditions at $V_{DD} = 3.3V$, $T_a = 25 \pm 2 \text{ }^\circ\text{C}$, DC Current and $f_v = 60 \text{ Hz}$, whereas a power dissipation check pattern below is displayed.

a. White Pattern



Active Area

b. Black Pattern



Active Area

BACKLIGHT UNIT

$T_a = 25 \pm 2 \text{ }^\circ\text{C}$

Parameter	Symbol	Value			Unit	Note
		Min	Type	Max		
Power Consumption	P_L	-	14.95	-	W	$I_L = 872$
LED Life Time	L_{BL}	70000			Hrs	

BLOCK DIAGRAM

TFT LCD MODULE

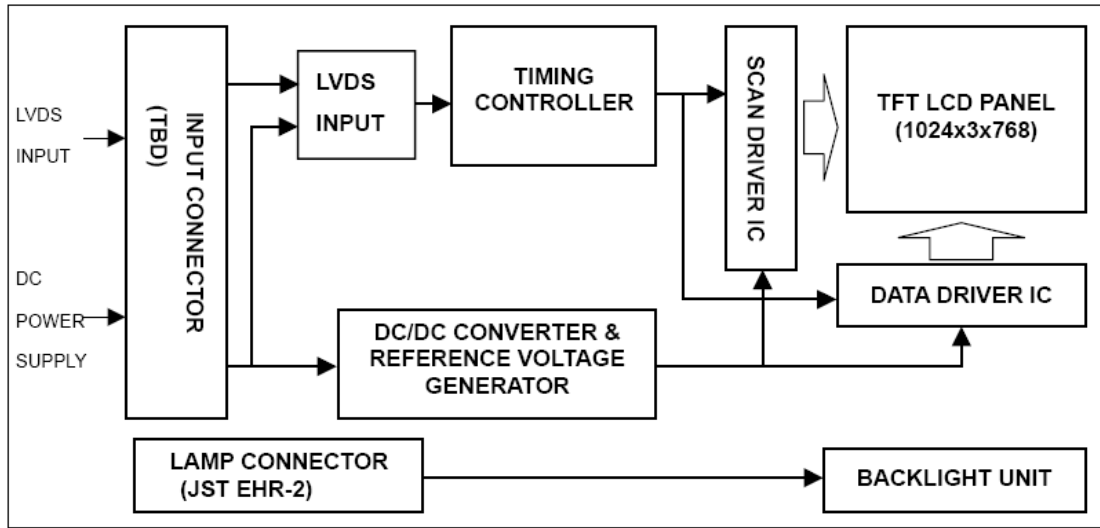

INPUT TERMINAL PIN ASSIGNMENT

TFT LCD MODULE

Pin No.	Symbol	Function	Polarity	Note
1	VDD	Power Supply +3.3V(typical)		
2	VDD	Power Supply +3.3V(typical)		
3	GND	Ground		
4	GND	Ground		
5	RX0-	LVDS Differential Data Input	Negative	
6	RX0+	LVDS Differential Data Input	Positive	
7	GND	Ground		
8	RX1-	LVDS Differential Data Input	Negative	
9	RX1+	LVDS Differential Data Input	Positive	
10	GND	Ground		
11	RX2-	LVDS Differential Data Input	Negative	
12	RX2+	LVDS Differential Data Input	Positive	
13	GND	Ground		
14	RXCLK-	LVDS Differential Data Input	Negative	
15	RXCLK+	LVDS Differential Data Input	Positive	
16	GND	Ground		
17	RX3-	LVDS Differential Data Input	Negative	
18	RX3+	LVDS Differential Data Input	Positive	
19	GND	Ground		
20	NC	tied to ground		

(1)Connector Part No.: [Hirose] DF14H-20P-1.25H

(2)Matching socket Part No.: [Hirose] DF14-20S-1.25C

BACKLIGHT UNIT

Pin	Symbol	Description	Color
1	Vcc	High Voltage	Red
2	GND	Ground	Black

Note (1) Connector Part No.: HD2505-02 or equivalent

Note (2) Matching Connector Part No.: TD2505-02 or equivalent

COLOR DATA INPUT ASSIGNMENT

The brightness of each primary color (red, green and blue) is based on the 8-bit gray scale data input for the color. The higher the binary input the brighter the color. The table below provides the assignment of color versus data input.

Color		Data Signal																							
		Red								Green								Blue							
		R7	R6	R5	R4	R3	R2	R1	R0	R7	R6	G5	G4	G3	G2	G1	G0	R7	R6	B5	B4	B3	B2	B1	B0
Basic Colors	Black	0	0	0	0	0	0	0	0	0	0	0	0	0	0	0	0	0	0	0	0	0	0	0	
	Red	1	1	1	1	1	1	1	1	0	0	0	0	0	0	0	0	0	0	0	0	0	0	0	
	Green	0	0	0	0	0	0	0	0	1	1	1	1	1	1	1	1	0	0	0	0	0	0	0	
	Blue	0	0	0	0	0	0	0	0	0	0	0	0	0	0	0	0	1	1	1	1	1	1	1	
	Cyan	0	0	0	0	0	0	0	0	1	1	1	1	1	1	1	1	1	1	1	1	1	1	1	
	Magenta	1	1	1	1	1	1	1	1	0	0	0	0	0	0	0	0	1	1	1	1	1	1	1	
	Yellow	1	1	1	1	1	1	1	1	1	1	1	1	1	1	1	1	0	0	0	0	0	0	0	
	White	1	1	1	1	1	1	1	1	1	1	1	1	1	1	1	1	1	1	1	1	1	1	1	
Gray Scale Of Red	Red(0) / Dark	0	0	0	0	0	0	0	0	0	0	0	0	0	0	0	0	0	0	0	0	0	0		
	Red(1)	0	0	0	0	0	0	0	1	0	0	0	0	0	0	0	0	0	0	0	0	0	0		
	Red(2)	0	0	0	0	0	0	1	0	0	0	0	0	0	0	0	0	0	0	0	0	0	0		
	⋮	⋮	⋮	⋮	⋮	⋮	⋮	⋮	⋮	⋮	⋮	⋮	⋮	⋮	⋮	⋮	⋮	⋮	⋮	⋮	⋮	⋮			
	⋮	⋮	⋮	⋮	⋮	⋮	⋮	⋮	⋮	⋮	⋮	⋮	⋮	⋮	⋮	⋮	⋮	⋮	⋮	⋮	⋮	⋮			
	⋮	⋮	⋮	⋮	⋮	⋮	⋮	⋮	⋮	⋮	⋮	⋮	⋮	⋮	⋮	⋮	⋮	⋮	⋮	⋮	⋮	⋮			
	Red(252)	1	1	1	1	1	1	0	1	0	0	0	0	0	0	0	0	0	0	0	0	0	0		
	Red(252)	1	1	1	1	1	1	1	0	0	0	0	0	0	0	0	0	0	0	0	0	0	0		
Red(252)	1	1	1	1	1	1	1	1	0	0	0	0	0	0	0	0	0	0	0	0	0	0			
Gray Scale Of Green	Green(0)/Dark	0	0	0	0	0	0	0	0	0	0	0	0	0	0	0	0	0	0	0	0	0	0		
	Green(1)	0	0	0	0	0	0	0	0	0	0	0	0	0	0	1	0	0	0	0	0	0	0		
	Green(2)	0	0	0	0	0	0	0	0	0	0	0	0	0	1	0	0	0	0	0	0	0	0		
	⋮	⋮	⋮	⋮	⋮	⋮	⋮	⋮	⋮	⋮	⋮	⋮	⋮	⋮	⋮	⋮	⋮	⋮	⋮	⋮	⋮	⋮			
	⋮	⋮	⋮	⋮	⋮	⋮	⋮	⋮	⋮	⋮	⋮	⋮	⋮	⋮	⋮	⋮	⋮	⋮	⋮	⋮	⋮	⋮			
	⋮	⋮	⋮	⋮	⋮	⋮	⋮	⋮	⋮	⋮	⋮	⋮	⋮	⋮	⋮	⋮	⋮	⋮	⋮	⋮	⋮	⋮			
	Green(252)	0	0	0	0	0	0	0	1	1	1	1	1	1	0	1	0	0	0	0	0	0	0		
	Green(252)	0	0	0	0	0	0	0	1	1	1	1	1	1	1	0	0	0	0	0	0	0	0		
Green(252)	0	0	0	0	0	0	0	1	1	1	1	1	1	1	1	0	0	0	0	0	0	0			
Gray Scale Of Blue	Blue(0) / Dark	0	0	0	0	0	0	0	0	0	0	0	0	0	0	0	0	0	0	0	0	0	0		
	Blue(1)	0	0	0	0	0	0	0	0	0	0	0	0	0	0	0	0	0	0	0	0	0	1		
	Blue(2)	0	0	0	0	0	0	0	0	0	0	0	0	0	0	0	0	0	0	0	0	0	1		
	⋮	⋮	⋮	⋮	⋮	⋮	⋮	⋮	⋮	⋮	⋮	⋮	⋮	⋮	⋮	⋮	⋮	⋮	⋮	⋮	⋮	⋮			
	⋮	⋮	⋮	⋮	⋮	⋮	⋮	⋮	⋮	⋮	⋮	⋮	⋮	⋮	⋮	⋮	⋮	⋮	⋮	⋮	⋮	⋮			
	⋮	⋮	⋮	⋮	⋮	⋮	⋮	⋮	⋮	⋮	⋮	⋮	⋮	⋮	⋮	⋮	⋮	⋮	⋮	⋮	⋮	⋮			
	Blue(252)	0	0	0	0	0	0	0	0	0	0	0	0	0	0	1	1	1	1	1	1	1	0		
	Blue(252)	0	0	0	0	0	0	0	0	0	0	0	0	0	0	1	1	1	1	1	1	1	0		
Blue(252)	0	0	0	0	0	0	0	0	0	0	0	0	0	0	1	1	1	1	1	1	1	1			

Note (1) 0: Low Level Voltage, 1: High Level Voltage

INTERFACE TIMING

INPUT SIGNAL TIMING SPECIFICATIONS

The input signal timing specifications are shown as the following table and timing diagram.

Signal	Item	Symbol	Min.	Typ.	Max.	Unit	Note
DCLK	Pixel Clock	$1/T_C$	-	65	80	MHz	-
DE	Vertical Total Time	T_V	780	806	1200	T_H	-
	Vertical Address Time	T_{VD}	768	768	768	T_H	-
	Horizontal Total Time	T_H	140	1344	1600	T_C	-
	Horizontal Address Time	T_{HD}	024	1024	1024	T_C	-

Note (1) Because this module is operated by DE only mode, Hsync and Vsync input signals should be set to low logic level or ground. Otherwise, this module would operate abnormally.

INPUT SIGNAL TIMING DIAGRAM

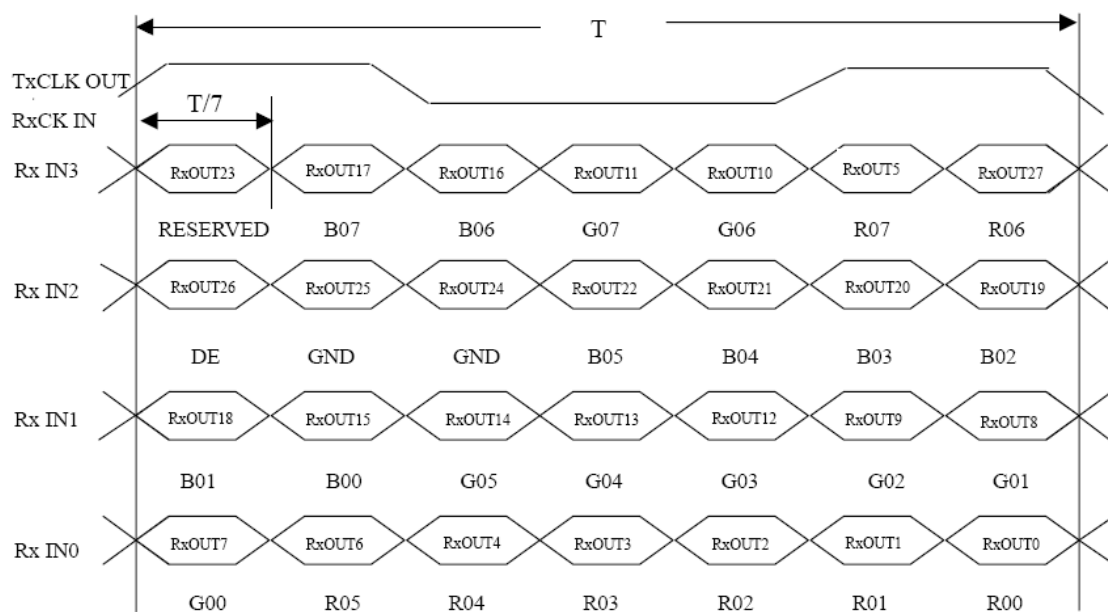
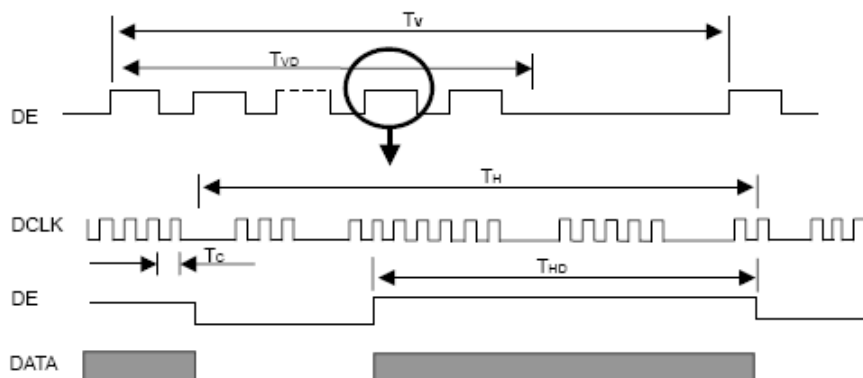

POWER ON/OFF SEQUENCE

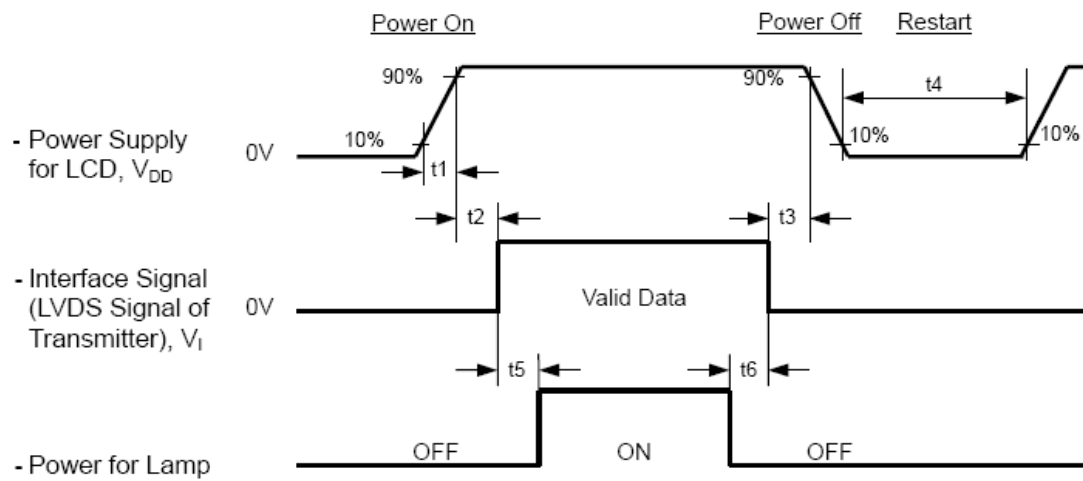

Timing Specifications:

$$0.5 < t_1 \leq 10 \text{ msec}$$

$$0 < t_2 \leq 50 \text{ msec}$$

$$0 < t_3 \leq 50 \text{ msec}$$

$$t_4 \geq 500 \text{ msec}$$

$$t_5 \geq 200 \text{ msec}$$

$$t_6 \geq 200 \text{ msec}$$

Note (1) Please avoid floating state of interface signal at invalid period.

Note (2) When the interface signal is invalid, be sure to pull down the power supply of LCD V_{DD} to 0 V.

Note (3) The Backlight inverter power must be turned on after the power supply for the logic and the interface signal is valid. The Backlight inverter power must be turned off before the power supply for the logic and the interface signal is invalid.

OPTICAL CHARACTERISTICS

TEST CONDITIONS

Item	Symbol	Value	Unit
Ambient Temperature	Ta	25±2	°C
Ambient Humidity	Ha	50±10	%RH
Supply Voltage	V _{DD}	3.3	V
Input Signal	According to typical value in "3. ELECTRICAL CHARACTERISTICS"		
LED Current	I _L	872	mA
LED Working Frequency	F _L	120	KHz
LED Driver Board	Litemax LID15A02		

OPTICAL SPECIFICATIONS

Item	Symbol	Condition	Min	Typ	Max	Unit	Note
Color Chromaticity	Red	R _x	θ _x =0°,θ _y =0° CS-1000T	Typ- 0.03	0.603	Typ+ 0.03	(1),(6)
		R _y			0.371		
	Green	G _x			0.375		
		G _y			0.541		
	Blue	B _x			0.165		
		B _y			0.084		
	White	W _x			0.341		
		W _y			0.329		
	Center Luminance of White	L _c					
Contrast Ratio	CR		480	700		-	(2),(6)
Response Time	T _R	θ _x =0°,θ _y =0°	-	8	13	ms	(3)
	T _F		-	17	22		
White Variation	δW	θ _x =0°,θ _y =0°	-	1.25	1.4	-	(6),(7)
Cross Talk	CT	BM-5A	-	-	5.0	%	(5),(6)
Viewing Angle	Horizontal	θ _{x+}	CR≥10 BM-5A	70	80	Deg.	(1),(6), (8)
		θ _{x-}		70	80		
	Vertical	θ _{y+}		70	80		
		θ _{y-}		70	80		

Note (1) Definition of Viewing Angle (θ_x , θ_y):

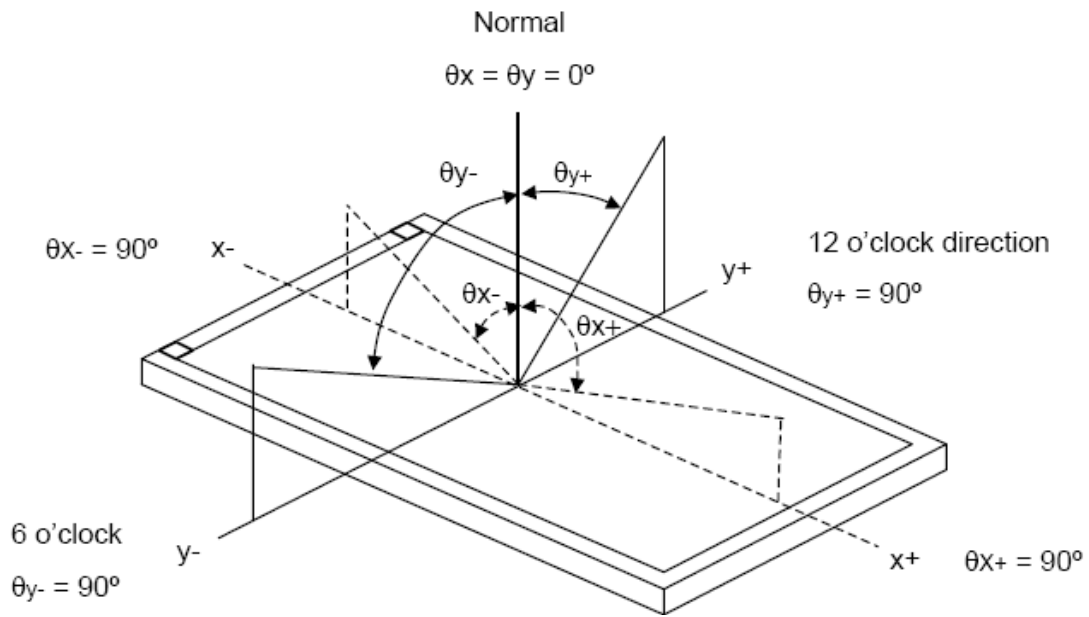

Note (2) Definition of Contrast Ratio (CR):

The contrast ratio can be calculated by the following expression.

$$\text{Contrast Ratio (CR)} = L_{255} / L_0$$

L_{255} : Luminance of gray level 255

L_0 : Luminance of gray level 0

$$CR = CR(1)$$

$CR(X)$ is corresponding to the Contrast Ratio of the point X at Figure in Note (5).

Note (3) Definition of Response Time (T_R , T_F):

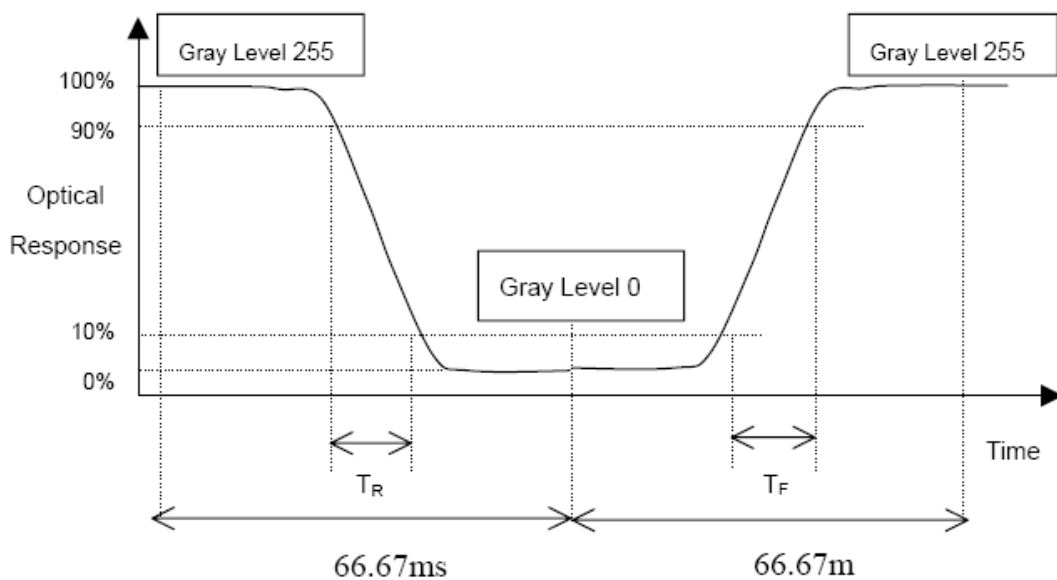

Note (4) Definition of Luminance of White (L_C):
 Measure the luminance of gray level 255 at center point

$$L_C = L \quad (5)$$

$L(x)$ is corresponding to the luminance of the point X at Figure in Note (7).

Note (5) Definition of Cross Talk (CT):

$$CT = |Y_B - Y_A| / Y_A \times 100 (\%)$$

Where:

Y_A = Luminance of measured location without gray level 0 pattern (cd/m^2)

Y_B = Luminance of measured location with gray level 0 pattern (cd/m^2)

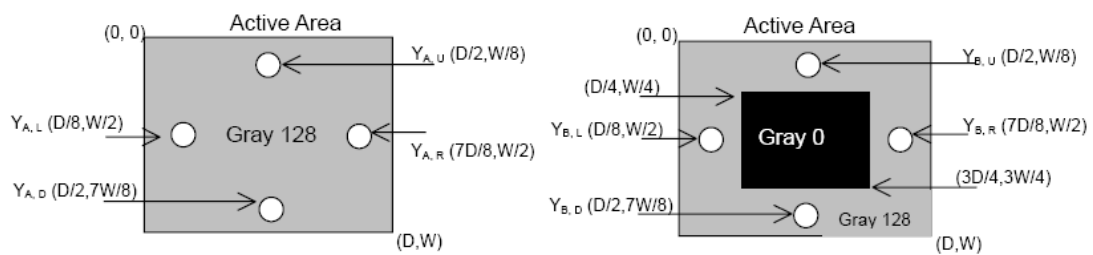

Note (6) Measurement Setup: The LCD module should be stabilized at given temperature for 20 minutes to avoid abrupt temperature change during measuring. In order to stabilize the luminance, the measurement should be executed after lighting Backlight for 20 minutes in a windless room.

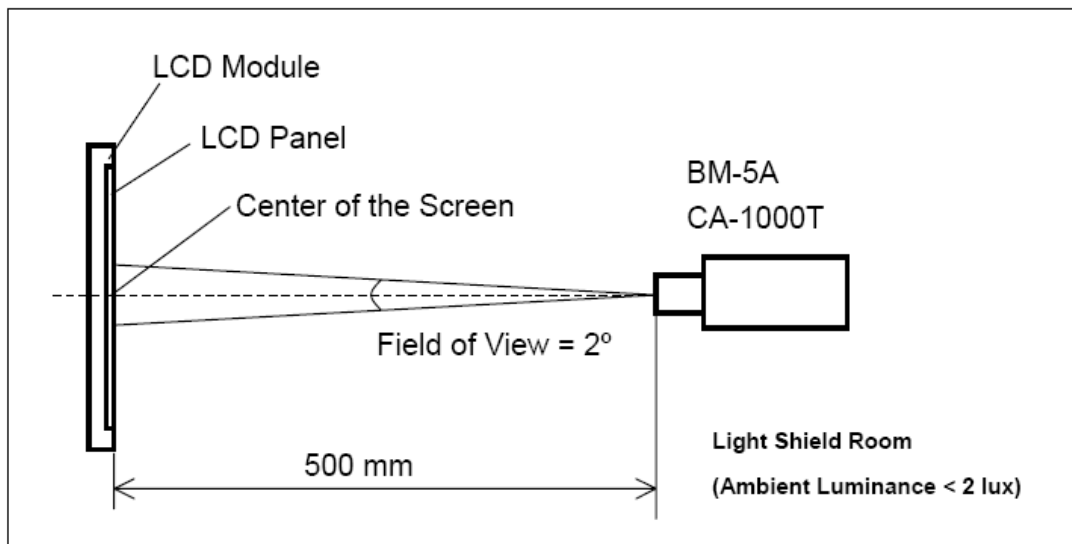

Note (7) Definition of luminance measured points: Measure the luminance of gray level 255 at point L(1) Definition of White Variation (δW): Measure the luminance of gray level 255 at 9 points

$$\delta W = \frac{\text{Maximum [L (1), L (6), L (7), L (8), L (9), L (10), L (11), L (12), L (13)]}}{\text{Minimum [L (1), L (6), L (7), L (8), L (9), L (10), L (11), L (12), L (13)]}}$$

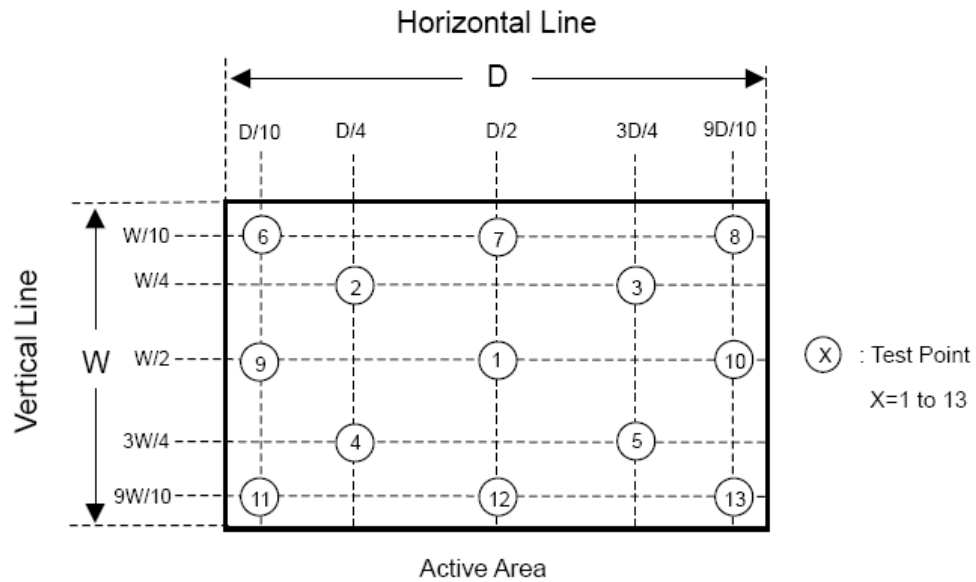

Note (8) TN type has Gray scale inversion occurs at $\theta_y: -40^\circ$

PRECAUTIONS

HANDLING PRECAUTIONS

- (1) The module should be assembled into the system firmly by using every mounting hole. Be careful not to twist or bend the module.
- (2) While assembling or installing modules, it can only be in the clean area. The dust and oil may cause electrical short or damage the polarizer.
- (3) Use fingerstalls or soft gloves in order to keep display clean during the incoming inspection and assembly process.
- (4) Do not press or scratch the surface harder than a HB pencil lead on the panel because the polarizer is very soft and easily scratched.
- (5) If the surface of the polarizer is dirty, please clean it by some absorbent cotton or soft cloth. Do not use Ketone type materials (ex. Acetone), Ethyl alcohol, Toluene, Ethyl acid or Methyl chloride. It might permanently damage the polarizer due to chemical reaction.
- (6) Wipe off water droplets or oil immediately. Staining and discoloration may occur if they left on panel for a long time.
- (7) If the liquid crystal material leaks from the panel, it should be kept away from the eyes or mouth. In case of contacting with hands, legs or clothes, it must be washed away thoroughly with soap.
- (8) Protect the module from static electricity, it may cause damage to the C-MOS Gate Array IC.
- (9) Do not disassemble the module.
- (10) Do not pull or fold the lamp wire.
- (11) Pins of I/F connector should not be touched directly with bare hands.

STORAGE PRECAUTIONS

- (1) High temperature or humidity may reduce the performance of module. Please store LCD module within the specified storage conditions.
- (2) It is dangerous that moisture come into or contacted the LCD module, because the moisture may damage LCD module when it is operating.
- (3) It may reduce the display quality if the ambient temperature is lower than 10 °C. For example, the response time will become slowly, and the starting voltage of lamp will be higher than the room temperature.

OPERATION PRECAUTIONS

- (1) Do not pull the I/F connector in or out while the module is operating.
- (2) Always follow the correct power on/off sequence when LCD module is connecting and operating. This can prevent the CMOS LSI chips from damage during latch-up.