



LITEMAX DLF/DLH1815

Sunlight Readable 18.5" LED B/L LCD

User Manual

(1st Edition 2010/7/27)

All information is subject to change without notice.

Approved by	Checked by	Prepared by
Ming	Jacky	Max

LITEMAX Electronics Inc.
8F, No.137, Lane 235, Bau-chiau Rd.,
Shin-dian City, Taipei County, Taiwan R.O.C.
Tel : 886-2-8919-1858
Fax: 886-2-8919-1300
Homepage: <http://www.litemax.com.tw>

RECORD OF REVISION

Version and Date	Page	Old Description	New Description	Remark
Jul,27,2010	all		Preliminary Release	

Contents

RECORD OF REVISION	2
Contents	3
1.0 GENERAL DESCRIPTION	4
1.1 FEATURES	4
1.2 GENERAL SPECIFICATIONS	4
1.3 ABSOLUTE MAXIMUM RATINGS	4
1.4 ELECTRICAL SPECIFICATION	5
2.0 POWER SEQUENCE	5
3.0 SIGNAL TIMING SPECIFICATIONS	6
4.0 SIGNAL TIMING WAVEFORMS OF INTERFACE SIGNAL	7
5.0 CONNECTOR and PIN ASSIGNMENT	8
6.0 OPTICAL SPECIFICATION	10
7.0 MEASURING METHOD	11
8.0 LED DRIVING BOARD SPECIFICATIONS	13
9.0 AD2662GDVAR SPECIFICATIONS(DLH1815 only)	16
9.1 General Description	16
9.2 Outline Dimensions	17
9.3 AD2662 Board Pin Define	20
J3: Panel connector.....	20
CN3: DVI-D INPUT Connector	20
CN5: DVI-D Connector (16pin 2.0mm).....	21
CN2: Analog RGB Input connector (D-SUB 15Pin)	21
CN4: Analog RGB Input connector (13pin connector)	21
JS1: Power DIN(12V).....	21
JS1: Power Jack (12V).....	21
J1: Power connector (12V) (6PIN 2.0mm)	22
J8: Power connector (5V/12v)(4PIN 2.0mm)	22
J2: Inverter Connector(8PIN 2.0mm).....	22
J7, J9: FAN (2PIN 2.0mm).....	22
J6: Key Pad (9PIN 2.0mm).....	22
J10: Speaker Connector (4PIN 2.0mm)	22
J11 Extern Funtion Connector (11P X 2PIN 2.0mm).....	23
J5: Ambient (3PIN 2.0mm).....	23
J4: VR connector (3PIN 2.0mm)	23
J12: IR Connector(3PIN 2.0mm).....	23
JP1: PANEL VCC (3PIN 2.54mm)	23
9.4 I/O BOARD Pin Define	24
9.5 IR Receive Board Pin Define	25
9.6 DC Characteristics	25
9.7 OSD menu	26
10.0 MECHANICAL DRAWING	31
11.0 PRECAUTIONS	32

1.0 GENERAL DESCRIPTION

DLF/DLH1815 is 18.5" wide color a-Si TFT-LCD module as active switching devices with 1,000nits LED backlight powered by Durapixel™ technology. This module has a 18.5 inch diagonally measured active area with WXGA resolutions (1366* 768). Each pixel is divided into RED, GREEN, BLUE dots which are arranged in vertical stripe and this module can display 16.7M colors.

1.1 FEATURES

- Sunlight Readable
- LED Backlight
- High Shock & Vibration Resistance
- Low Power Consumption
- Wide Operation Temperature.
- High Uniformity (90%)
- Low EMI Noise
- Wide Dimming
- Life Expectancy (70,000hrs)

1.2 GENERAL SPECIFICATIONS

Description	18.5" Wide TFT LCD, LED Backlight 1000nits, WXGA
Display Area (mm)	409.8(h) x 230.4(v) mm
Brightness	1000 cd/m ²
Resolution	1366x768 (WXGA)
Contrast Ratio	1000 : 1
Pixel Pitch (mm)	0.3(H) x 0.3(V)
Viewing Angle	+85°~-85°(H), +80°~-80°(V)
Display Colors	16.7M
Response Time (Typical)	5ms
Sync	LVDS
Power Consumption	25W
Dimensions (mm)	430.37x254.6x16.5
Weight (Net)	1.33Kg

1.3 ABSOLUTE MAXIMUM RATINGS

TFT LCD Module

Item	Symbol	Min	Max	Unit
Logic/LCD Drive Voltage	VDD	4.5	+5.5	[Volt]

ABSOLUTE RATINGS OF ENVIRONMENT

Item	Symbol	Min.	Max.	Unit
Operating Temperature	TOP	0	+50	[°C]
Operation Humidity	HOP	5	90	[%RH]
Storage Temperature	TST	-20	+60	[°C]
Storage Humidity	HST	5	90	[%RH]

1.4 ELECTRICAL SPECIFICATION

Symbol	Parameter	Min	Typ	Max	Unit	Conditions
VDD	Logic/LCD Drive Voltage	4.5	5.0	5.5	[Volt]	+/-10%
IDD	Input Current	-	0.84	1	[A]	VDD= 5.0V, All Black Pattern At 60Hz,
PDD	VDD Power	-	4.2	5	[Watt]	VDD= 5.0V, All Black Pattern At 60Hz
IRush	Inrush Current	-	-	3	[A]	Note 1
VDDrp	Allowable Logic/LCD Drive Ripple Voltage	-	-	350	[mV] p-p	VDD= 5.0V, All Black Pattern At 60Hz

2.0 POWER SEQUENCE

SEQUENCE OF POWER SUPPLIES AND SIGNALS

VDD power and lamp on/off sequence are as follows. Interface signals are also shown in the chart. Signals from any system shall be Hi-Z state or low level when VDD is off.

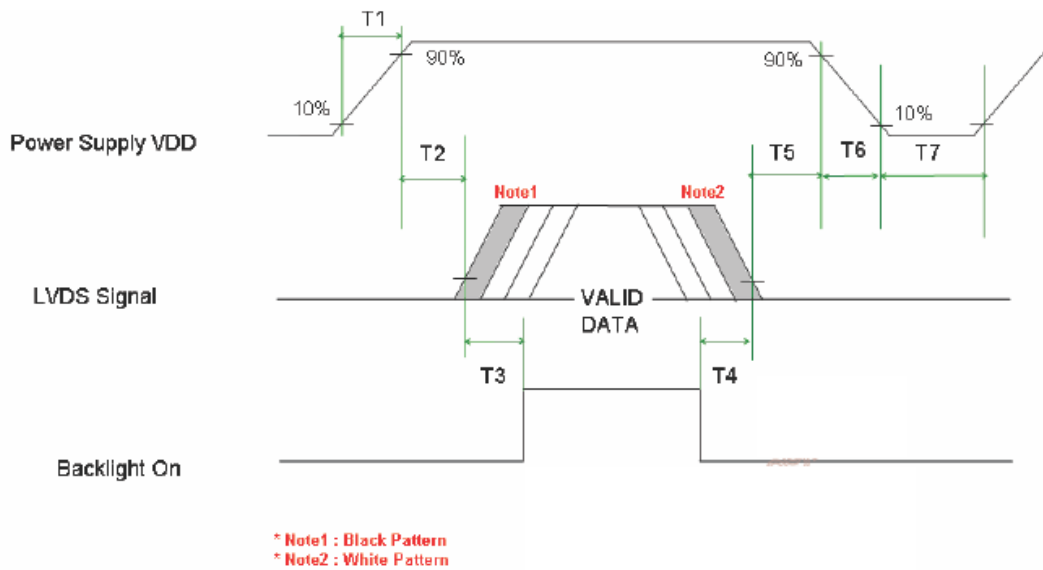

Parameter	Value			Unit
	Min.	Typ.	Max.	
T1	0.5	-	10	[msec]
T2	0	40	50	[msec]
T3	200	-	-	[msec]
T4	200	-	-	[msec]
T5	0.5	16	50	[msec]
T6	-	-	100	[msec]
T7	1000	-	-	[msec]

3.0 SIGNAL TIMING SPECIFICATIONS

PIXEL FORMAT IMAGE

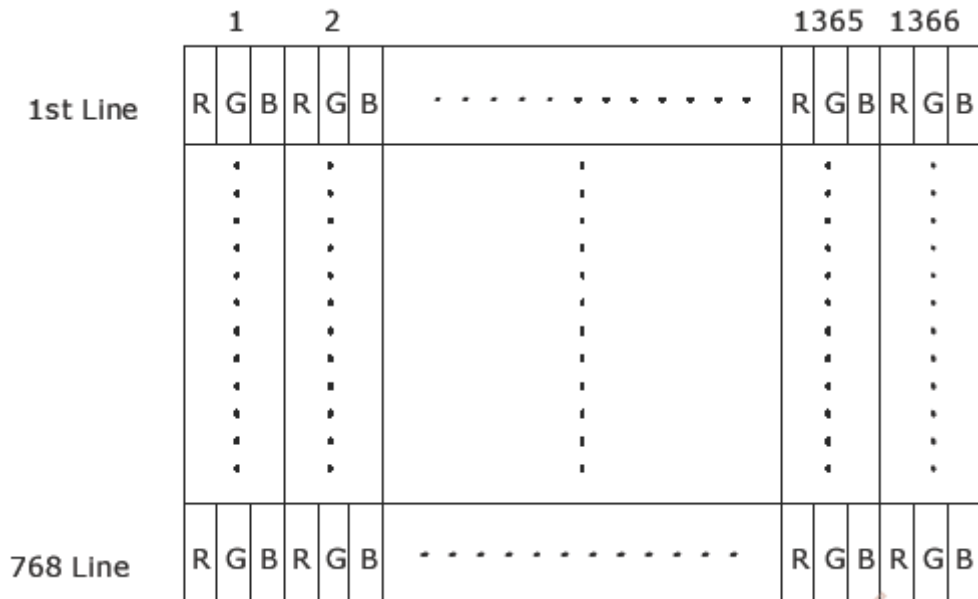

INPUT DATA FORMAT

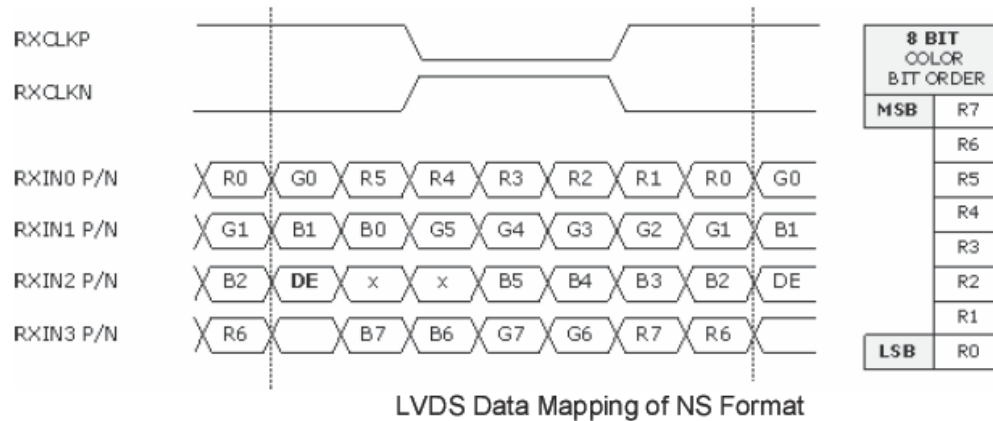

LVDS Data Mapping of NS Format

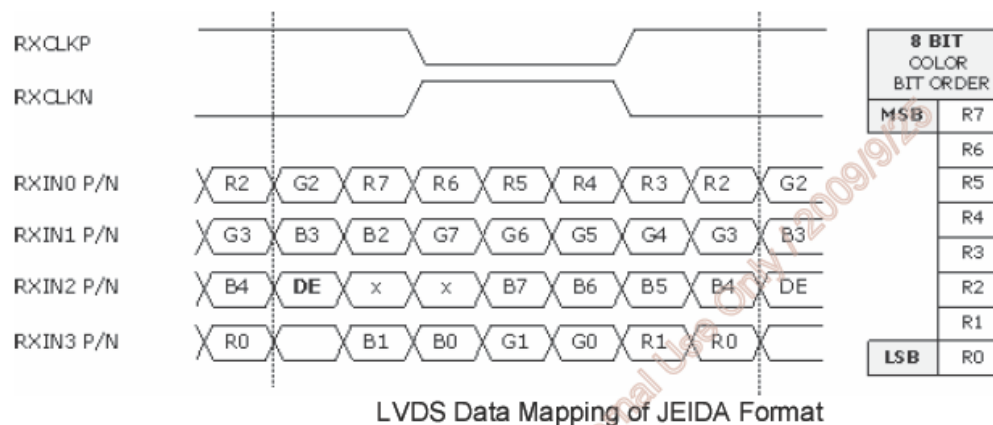

LVDS Data Mapping of JEIDA Format

Note1: Normally, DE, VS, HS on EVEN channel are not used.
 Note2: 8-bits signal input.

5.0 CONNECTOR and PIN ASSIGNMENT

LVDS Connection

Receiver: SN75LVDS82 or equivalent

Transmitter SN75LVDS83 or equivalent

PIN #	SIGNAL NAME	DESCRIPTION
1	NC	No contact (For AUO internal use)
2	NC	No contact (For AUO internal use)
3	NC	No contact (For AUO internal use)
4	GND	Power Ground
5	RXIN0-	Negative LVDS differential data input (0)
6	RXIN0+	Positive LVDS differential data input (0)
7	GND	Power Ground
8	RXIN1-	Negative LVDS differential data input (1)
9	RXIN1+	Positive LVDS differential data input (1)
10	GND	Power Ground
11	RXIN2-	Negative LVDS differential data input (2)
12	RXIN2+	Positive LVDS differential data input (2)
13	GND	Power Ground
14	RXCLKIN-	Negative LVDS differential clock input (clock)
15	RXCLKIN+	Positive LVDS differential data input (clock)
16	GND	Power Ground
17	RXIN3-	Negative LVDS differential data input (3)
18	RXIN3+	Positive LVDS differential data input (3)
19	GND	Power Ground
20	NC	No contact (For AUO internal use)
21	NC	No contact (For AUO internal use)
22	NC	No contact (For AUO internal use)
23	GND	Power Ground
24	GND	Power Ground
25	GND	Power Ground
26	VCC	+5V power supply
27	VCC	+5V power supply
28	VCC	+5V power supply
29	VCC	+5V power supply
30	VCC	+5V power supply

TFT LCD Module

Connector Name / Designation	Interface Connector / Interface card
Manufacturer	JAE or CHIEF LAND
Type Part Number	FI-XB30SRL-HF11(JAE) / 093F30-B0T01A(CHIEF LAND)
Mating Housing Part Number	FI-X30HL(JAE) (Locked Type) FI-X30H (JAE)(Unlocked Type)

PIN ASSIGNMENT

Pin#	Signal Name	Pin#	Signal Name
1	NC	2	NC
3	NC	4	GND
5	RXIN0-	6	RXIN0+
7	GND	8	RXIN1-
9	RXIN1+	10	GND
11	RXIN2-	12	RXIN2+
13	GND	14	RXCLKIN-
15	RXCLKIN+	16	GND
17	RXIN3-	18	RXIN3+
19	GND	20	NC
21	NC	22	NC
23	GND	24	GND
25	GND	26	VCC
27	VCC	28	VCC
29	VCC	30	VCC

LED BACKLIGHT CONNECTOR

Connector Name / Designation	Driver Board Connector
Manufacturer	ENTERY INDUSTRIAL CO., LTD
Mating Type Part Number	7083K-F10Y-00

PIN ASSIGNMENT

Pin no.	Signal name
1	No contact
2	IRLED (current out)
3	IRLED (current out)
4	IRLED (current out)
5	VLED (voltage in)
6	VLED (voltage in)
7	IRLED (current out)
8	IRLED (current out)
9	IRLED (current out)
10	No contact

6.0 OPTICAL SPECIFICATION

The optical characteristics are measured under stable conditions at 25°C:

Item	Unit	Conditions	Min.	Typ.	Max.	Note
Viewing Angle	[degree]	Horizontal (Right) CR = 10 (Left)	150	170	-	2
		Vertical (Up) CR = 10 (Down)	140	160	-	
Contrast ratio		Normal Direction	600	1000	-	3
Response Time	[msec]	Raising Time (T_{rR})	-	3.6	5.7	4
		Falling Time (T_{rF})	-	1.4	2.3	
		Raising + Falling	-	5	8	
Color / Chromaticity Coordinates (CIE)		Red x	0.618	0.648	0.678	5
		Red y	0.309	0.339	0.369	
		Green x	0.262	0.292	0.322	
		Green y	0.573	0.603	0.633	
		Blue x	0.113	0.143	0.173	
		Blue y	0.040	0.070	0.100	
Color Coordinates (CIE) White		White x	0.283	0.313	0.343	
		White y	0.299	0.329	0.359	
Central Luminance	[cd/m ²]		1000	-	6	
Luminance Uniformity	[%]		75	80	-	7
Crosstalk (in 60Hz)	[%]				1.5	8
Flicker	dB				-20	9

7.0 MEASURING METHOD

(1) Definition of Viewing Angle (θ_x, θ_y):

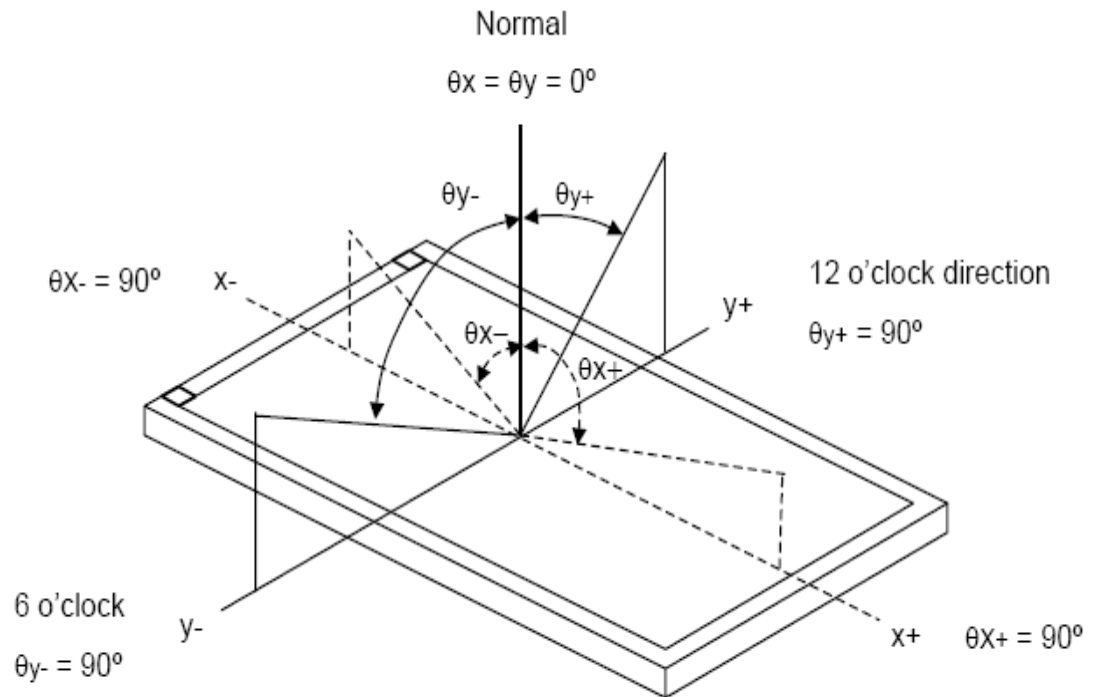

(2) Definition of Test Point :

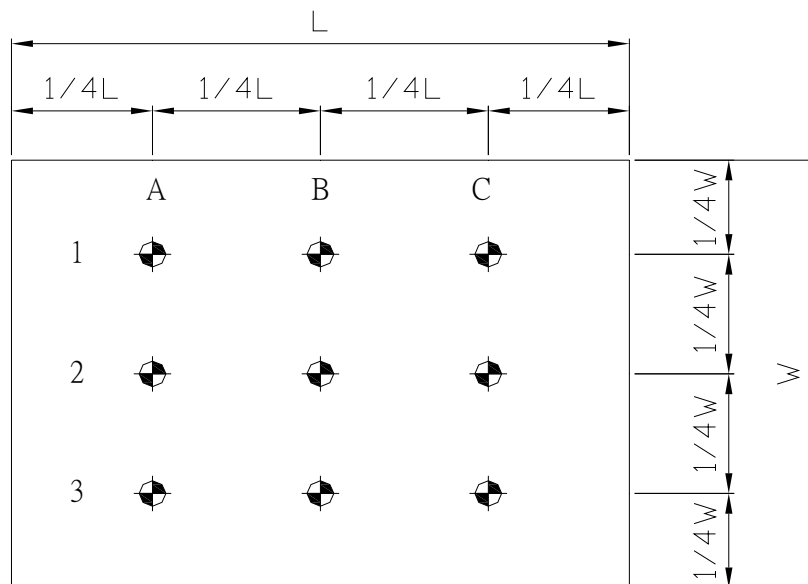

Active Area

(3) BM-7 Measurement Setup:

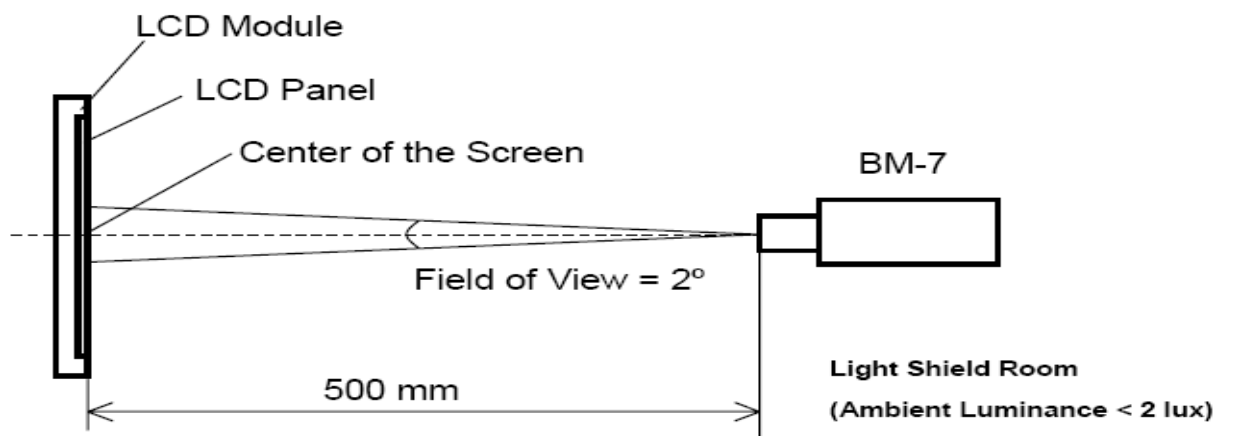

(4) Klein K-10 Measurement Setup:

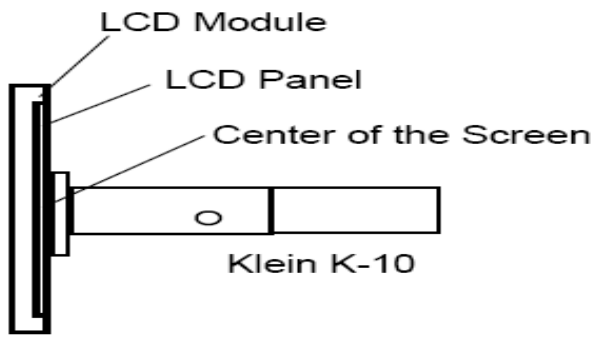

8.0 LED DRIVING BOARD SPECIFICATIONS

1. LED Application

This specification is applied to LED converter unit for DLF/DLH1815 (1000 nits) LED backlight

2. Operating Characteristics

Item	Symbol	Conditions	MIN.	TYP.	MAX.	Unit	Remark
Input Voltage	Vin		10.0	12.0	15.0	V	
Input Current (Low Brightness)	IinL	VIN=12V,Vadj=5V	0.0	-----	-----	mA	
Input Current (High Brightness)	IinH	VIN=12V,Vadj=0V	2.66	2.2	1.87	A	
LED Current (Low Brightness)	IoutL	VIN=12V,Vadj=5V	0.0	-----	-----	Arms	
LED Current (High Brightness)	IoutH	VIN=12V,Vadj=0V	1.028	1.028	1.028	A	
Working Frequency	Freq	VIN=12V,Vadj=0V	517.75	545	572.25	KHZ	
PWM Frequency	Freq	VIN=12V	180	200	220	HZ	
Brightness Control	Vadj	Connection of Voltage	0.5	-----	4.8	V	
ON/OFF Control	Von/off	Normal Operation	2	-----	5	V	
Output Voltage	Vout	VIN=12V,Vadj=0V	24.12	24.05	23.92	V	
Efficiency	η	VIN=12V,Vadj=0V	93.22	93.65	93.93	%	

Note 1:Efficiency = [(IoutH* Vout)/(IinH* Vin)] * 100%,Tolerance \pm 0.5%

3. Environment

Operation Temperature	0 ~ 50°C
Operation Humidity	% Max.RH
Storage Temperature	-20 ~ 60°C
Storage Humidity	% Max.RH

4. Connector Socket

4-1. Input Connector: J3 (JST SM08B-SRSS-TB or Compatible):

PIN No	Symbol	Description
1	Vin	DC+12V
2	Vin	DC+12V
3	Vin	DC+12V
4	GND	Ground
5	GND	Ground
6	GND	Ground
7	Brightness	Brightness Control 5V~0V
8	Control	ON/OFF Control 0.8V(OFF) 2.0~5.0V(ON)

4-2 . Output Connector :J1,J2(JST S 2B-ZR-SM2-TF or Compatible)

:

PIN NO	Symbol	Description
1	Output	LED High Voltage(+)
2	Output	LED Low Voltage (-)

5. Mechanical Characteristics

Dimension: 70mm*30mm*5mm

INPUT CONNECTOR

J3:

- PIN1:VIN
- PIN2:VIN
- PIN3:VIN
- PIN4:GND
- PIN5:GND
- PIN6:GND
- PIN7:BRIGHTNESS
- PIN8:ON/OFF

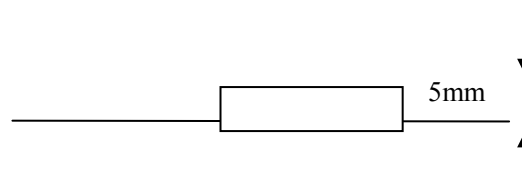
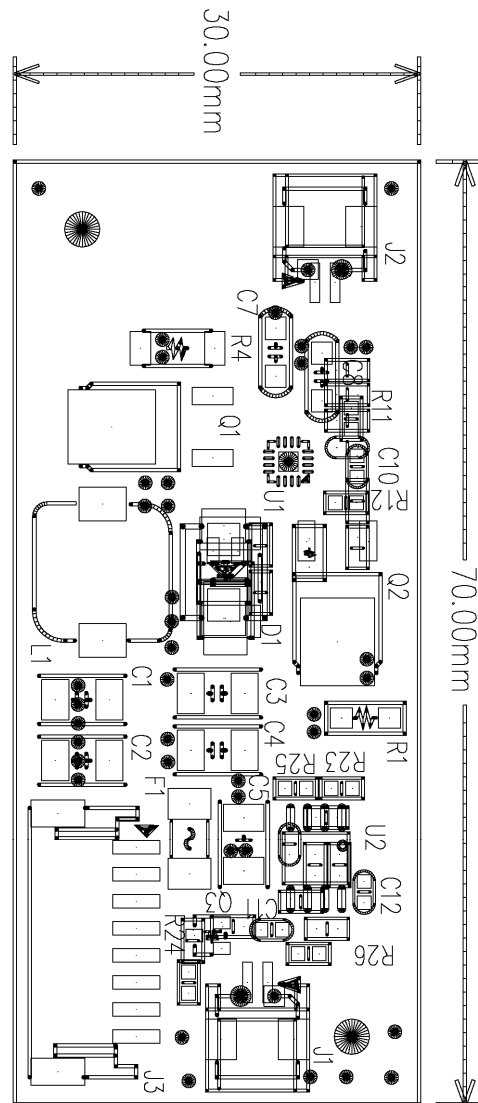

9.0 AD2662GDVAR SPECIFICATIONS(DLH1815 only)

We developed this A/D board to support industrial high brightness and commercial applications. This A/D board has many functions. It has an external luminance sensor as an option, an optional VR button to control brightness, fan rotation and RS232. Rev.1 is European RoHS compliant.

9.1 General Description

- Max Resolution Up To WUXGA
- Analog RGB Input up to 205MHz
- ULTRA-RELIABLE DVI INPUT
- Dual/single LVDS interface
- Support Panel DC5V or 3.3V, 12V Output
- External Fan Control by Software
- OSD Control
- Inverter Analog or PWM Dimming Control
- *External V.R. brightness control (optional)
- *External light sensor brightness control (optional)
- *External RS232 control (optional)
- Input Power 12V DC
- CBVS, S-VIDEO, **YCbCr (optional) INPUT
- Audio in and b2Wx2 Audio Out(optional)
- IR Remove control

I/O BOARD 160mmX25mmX15mm

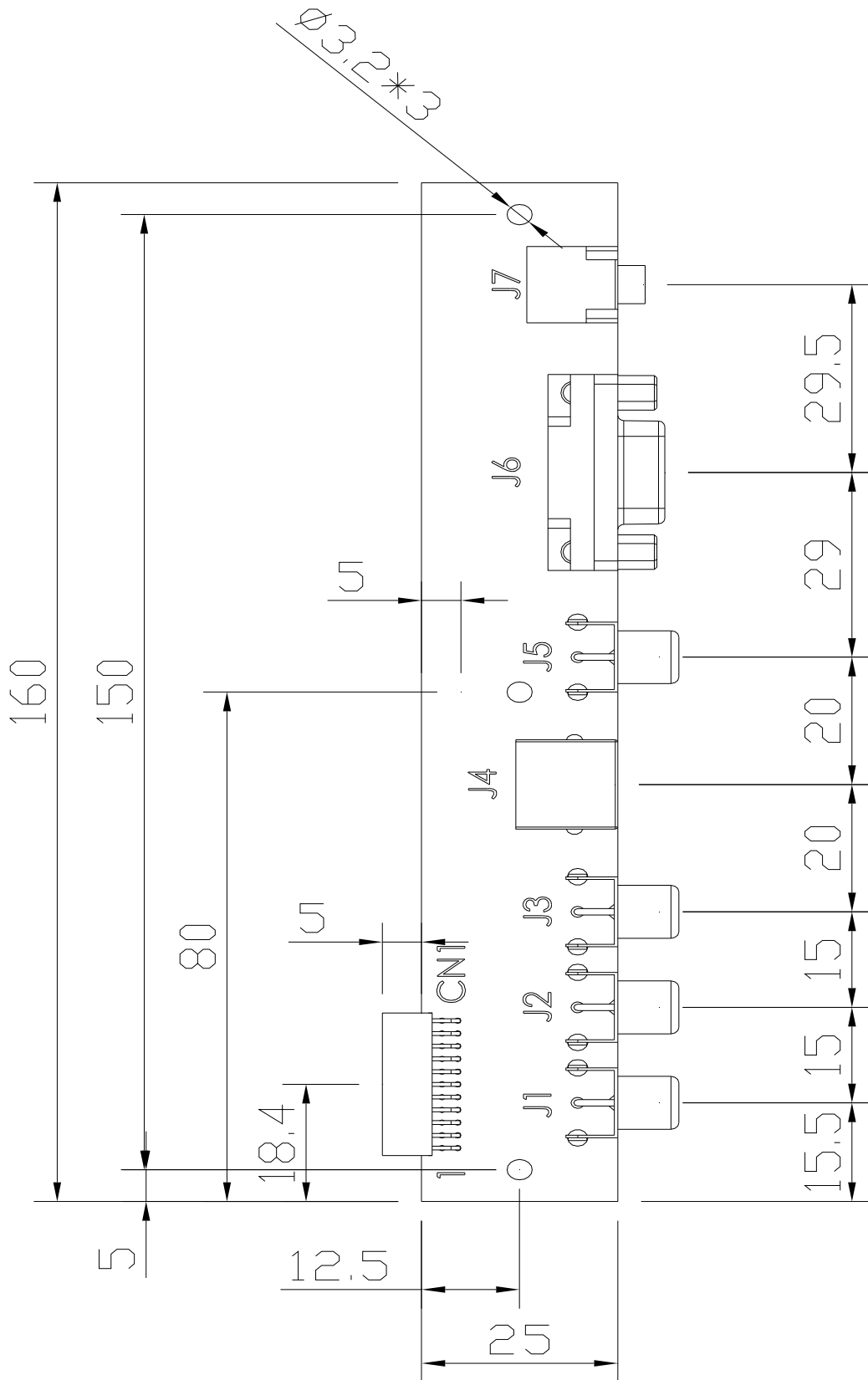

9.3 AD2662 Board Pin Define

J3: Panel connector

Pin No.	Function	Pin No.	Function
1	RxO0+	16	RxE1-
2	RxO0-	17	RxE2+
3	RxO1+	18	RxE2-
4	RxO1-	19	RxEC+
5	RxO2+	20	RxEC-
6	RxO2-	21	RxE3+
7	RxOC+	22	RxE3-
8	RxOC-	23	GND
9	RxO3+	24	GND
10	RxO3-	25	GND
11	GND	26	GND
12	GND	27	GND
13	RxE0+	28	PANEL-VCC
14	RxE0-	29	PANEL-VCC
15	RxE1+	30	PANEL-VCC

CN3: DVI-D INPUT Connector

Pin No.	Function	Pin No.	Function	Pin No.	Function
1	T.M.D.S. Data2-	9	T.M.D.S. Data1-	17	T.M.D.S. Data0-
2	T.M.D.S. Data2+	10	T.M.D.S. Data1+	18	T.M.D.S. Data0+
3	T.M.D.S. Data2/4 Shield	11	T.M.D.S. Data1/3 Shield	19	T.M.D.S. Data0/5 Shield
4	T.M.D.S. Data4-	12	T.M.D.S. Data3-	20	T.M.D.S. Data5-
5	T.M.D.S. Data4+	13	T.M.D.S. Data3+	21	T.M.D.S. Data5+
6	DDC Clock	14	+5V Power	22	T.M.D.S. Clock Shield
7	DDC Data	15	Ground (for +5V)	23	T.M.D.S. Clock+
8	Not Connected	16	Hot Plug Detect	24	T.M.D.S. Clock-

CN5: DVI-D Connector (16pin 2.0mm)

Pin No.	Function	Pin No.	Function	Pin No.	Function
1	RX2-	7	DDC_SDA	13	GND
2	RX2+	8	DDC_SCL	14	GND
3	RX1-	9	GND	15	DVI HP
4	RX1+	10	GND	16	DVI_5V
5	RX0-	11	RXC-		
6	RX0+	12	RXC+		

CN2: Analog RGB Input connector (D-SUB 15Pin)

Pin No.	Symbol	Description	Pin No.	Symbol	Description
1	RED	Analog Red	9	+5V	+5VDDC
2	GREEN	Analog Green	10	SGND	Sync GND
3	BLUE	Analog Blue	11	NCD	Reserved
4	GND	Reserved	12	SDA	DDC Serial Data
5	NC	VGA_CAB	13	HSYNC	Horizontal Sync
6	RED_RTN	Red Return	14	VSYNC	Vertical Sync
7	GREEN_RTN	Green Return	15	SCL	DDC Data Clock
8	BLUE_RTN	Blue Return			

CN4: Analog RGB Input connector (13pin connector)

Pin No.	Symbol	Description	Pin No.	Symbol	Description
1	SCL	DDC Data Clock	8	BGND	Blue Return
2	SDA	DDC Serial Data	9	BLUE	Analog Blue
3	GND	Reserved	10	GGND	Green Return
4	+5V	+5VDDC	11	GREEN	Analog Green
5	GND	Reserved	12	RGND	Red Return
6	VSYNC	Vertical Sync	13	RED	Analog Red
7	HSYNC	Horizontal Sync			

JS1: Power DIN(12V)

Pin No.	Function	Pin No.	Function
1	12VDC	2	12VDC
3	GND	4	GND

JS1: Power Jack (12V)

Pin No.	Function	Pin No.	Function
1	12VDC	2	12VDC

J1: Power connector (12V) (6PIN 2.0mm)

Pin No.	Function	Pin No.	Function
1	12VDC	4	GND
2	12VDC	5	GND
3	12VDC	6	GND

J8: Power connector (5V/12v)(4PIN 2.0mm)

Pin No.	Function	Pin No.	Function
1	5VDC	2	GND
3	12VDC	4	GND

J2: Inverter Connector(8PIN 2.0mm)

Pin No.	Symbol	Description	Pin No.	Symbol	Description
1	ON/OFF	Backlight ON/OFF	5	GND	GND
2	BRIGHT	Dimming adjust	6	12VDC	Input 12VDC
3	GND	GND	7	12VDC	Input 12VDC
4	GND	GND	8	12VDC	Input 12VDC

J7, J9: FAN (2PIN 2.0mm)

Pin No.	Function	Pin No.	Function
1	FAN(+)	2	GND

J6: Key Pad (9PIN 2.0mm)

Pin No.	Function	Pin No.	Function
1	POWER KEY	6	MENU KEY
2	GREEN LED	7	AUTO KEY
3	RED LED	8	GND
4	DOWN KEY	9	GND
5	UP KEY		

J10: Speaker Connector (4PIN 2.0mm)

Pin No.	Function	Pin No.	Function
1	SPK-R	2	GND
3	GND	4	SPK-L

J11 Extern Funtion Connector (11P X 2PIN 2.0mm)

Pin No.	Function	Pin No.	Function
1	Pb	2	Y
3	GND	4	Pr
5	GND	6	SY
7	GND	8	SC
9	GND	10	AV
11	GND	12	GND
13	TXD	14	RXD
15	GND	16	GND
17	GND	18	GND
19	Audio-L	20	Audio-R
21	GND	22	GND

J5: Ambient (3PIN 2.0mm)

Pin No.	Function	Pin No.	Function
1	3.3VDC	2	Sensor Out

J4: VR connector (3PIN 2.0mm)

Pin No.	Function	Pin No.	Function
1	3,3VDC	2	VR Out
3	GND		

J12: IR Connector(3PIN 2.0mm)

Pin No.	Function	Pin No.	Function
1	IR Out	3	3.3VDC
2	GND	4	

JP1: PANEL VCC (3PIN 2.54mm)

Pin No.	Function	Pin No.	Function
1-2	12V	5-6	3.3V
3-4	5V		

9.4 I/O BOARD Pin Define

J1:Component Y

Pin No.	Function	Pin No.	Function
1	Y	2	GND

J2:Component Cb

Pin No.	Function	Pin No.	Function
1	Cb	2	GND

J3:Component Cr

Pin No.	Function	Pin No.	Function
1	Cr	2	GND

J4:S-Video

Pin No.	Function	Pin No.	Function
1	GND	2	GND
3	Luminance	4	Chrominance

J5:Composite

Pin No.	Function	Pin No.	Function
1	Y	2	GND

J6:D-SUB9(RS232)

Pin No.	Function	Pin No.	Function
1	NC	2	TXD
3	RXD	4	NC
5	GND	6	NC
7	NC	8	NC
9	NC		

CN1:11P X 2 Connector

Pin No.	Function	Pin No.	Function
1	Component Cb	2	Component Y
3	GND	4	Component Cr
5	GND	6	S-Video Y
7	GND	8	S-Video C
9	GND	10	Composite
11	GND	12	GND
13	TXD	14	RXD
15	GND	16	GND
17	GND	18	GND
19	Audio IN(L)	20	Audio IN(R)

9.5 IR Receive Board Pin Define

J1: IR Connector

Pin No.	Function	Pin No.	Function
1	DATA OUT	2	GND
3	VCC	4	NC

9.6 DC Characteristics.

Power Consumption	10W	Note1
Operation Temperature	0~70	°C
Storage Temperature	-20~85	°C

Note: These values are for the A/D board body.

9.7 OSD menu

Here are some instructions for you to use the OSD (On Screen Display). By pressing the “menu”, you will see the below picture.

Timing shows resolution, H-frequency, and V-frequency of the panel. Version shows the firmware control version. This 2 information is not changeable by user.



There are 7 sub pages inside the OSD manual, Brightness, Signal select, Sound, Color, Image, Tools, and Exit.

When you press “menu” button, you enter the “Brightness” sub page. You will see 5 selections:



press “menu”



press “menu”



press “menu”



OSD Brightness:



press “right” key



press “menu” once, you can go into adjust the brightness. Press “left” you can dim down the brightness to “0”, while press “right” you can increase the brightness to “100”.



Ambient light sensor: press this Icon, must to accompany with Litemax ambient light sensor to auto dimming.(OPTION)



Potentiometer: press this icon, adjust VR function.(OPTION)



Ambient light sensor with OSD offset: press this Icon



Press ‘menu’ once, you can adjust min. luminance to fit your application (OPTION)



Contrast: Press “menu” and “right” you can adjust the contrast from “0” to “100” by pressing the “left” and “right”.



Exit: You can exit this sub menu back to normal screen.

Sound :

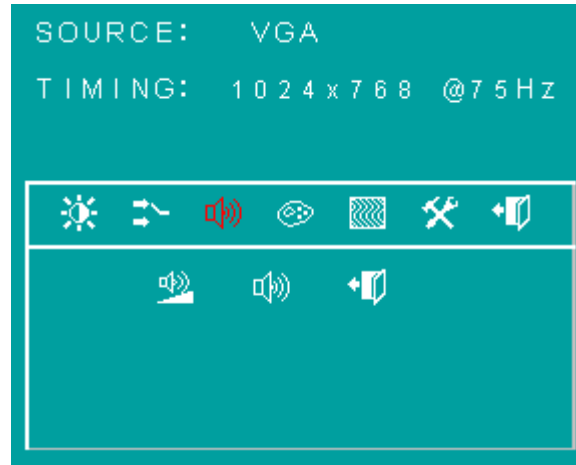

There are 3 options for “Sound” sub page.



Audio Volume: Audio volume adjustment.



Mute: You can mute the speaker by pressing this option.



Exit: back to the normal screen.



Auto Color: by press this “Auto Color” option, you can get the optimal color performance.



sRGB: Windows standard color setting.



Color Tempture: You can have 3 options in this selection.



Color Tempture User



Color Tempture_6500K



Color Tempture_9300K

“user mode”, “6500K” (Warm color scheme), “9300K (Cold color scheme).
Default is “user”, and inside all “R”, “G”, and “B” are set “100”



Exit: back to the normal screen.

Image :

Go into the “Image” page, you can see below picture.





Auto just: Pressing this option, the AD5621 will adjust the optimal frequency of horizontal and vertical. You will see “Auto tune....” On the screen for around 3 seconds.



Clock: If you are not satisfied about the Autotune result, you can adjust manually by “Clock”. The screen will be “wider” if you adjust this function.



Phase: If you see “double image” on characters, you can adjust “Phase” to make it perfect image.



HPos: You can shift the screen horizontally by this function.



Vpos: You can shift the screen vertically by this function.



Exit: Back to normal screen.

TOOLS :

On the “Tools” sub menu, you will see 4 icons.



Osd Control: Select this option, you will see 4 more options:

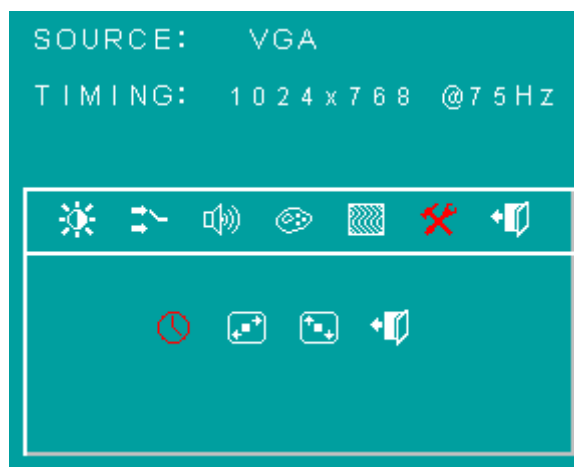



Osd_time: You can selection the time of OSD from 2 sec. to 16 sec.



Osd_HPos: You can move the OSD horizontally over the screen.



Osd_VPos: You can move the OSD Vertically over the screen.



Exit: back to main menu.



Factory_Reset: By pressing this, the screen will be back to the factory setting on very beginning and lost all the personal settings.



Sharpness: You can make the characters looks sharper.



Exit

BURNIN MODE :

Factory Burn-in mode: While your VGA cable is connected on the monitor, press “Menu” and Left and Right <” simultaneously, you will see “BURN IN MODE” on the center of the screen for 3 sec. Then unplug the VGA cable, the screen will show Red, Green, Blue, White, and Black in sequence automatically.

You can plug in the VGA signal cable, and re-plug the power connector to exit the burn-in mode.

KEY LOCK MODE :

OSD Lock Function: It is possible to lock all the OSD buttons to prevent unauthorized changes to occur by pressing “Menu” and “right >” buttons simultaneously. You will see the “lock” icon below on the center of the screen for 3 seconds. If any button is pushed after the lock function is initiated, the below icon will appear on the screen.'



To release the OSD lock, press “Menu” and “Right >”. The below icon will appear on the center of the screen for 3 seconds. Now all OSD keys are active again.

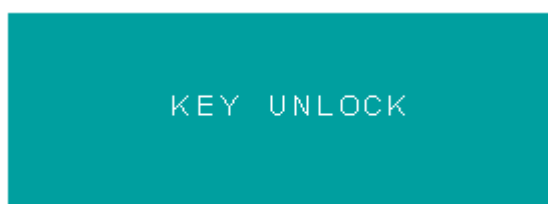

11.0 PRECAUTIONS

HANDLING PRECAUTIONS

- (1) The module should be assembled into the system firmly by using every mounting hole. Be careful not to twist or bend the module.
- (2) While assembling or installing modules, it can only be in the clean area. The dust and oil may cause electrical short or damage the polarizer.
- (3) Use fingerstalls or soft gloves in order to keep display clean during the incoming inspection and assembly process.
- (4) Do not press or scratch the surface harder than a HB pencil lead on the panel because the polarizer is very soft and easily scratched.
- (5) If the surface of the polarizer is dirty, please clean it by some absorbent cotton or soft cloth. Do not use Ketone type materials (ex. Acetone), Ethyl alcohol, Toluene, Ethyl acid or Methyl chloride. It might permanently damage the polarizer due to chemical reaction.
- (6) Wipe off water droplets or oil immediately. Staining and discoloration may occur if they left on panel for a long time.
- (7) If the liquid crystal material leaks from the panel, it should be kept away from the eyes or mouth. In case of contacting with hands, legs or clothes, it must be washed away thoroughly with soap.
- (8) Protect the module from static electricity, it may cause damage to the C-MOS Gate Array IC.
- (9) Do not disassemble the module.
- (10) Do not pull or fold the lamp wire.
- (11) Pins of I/F connector should not be touched directly with bare hands.

STORAGE PRECAUTIONS

- (1) High temperature or humidity may reduce the performance of module. Please store LCD module within the specified storage conditions.
- (2) It is dangerous that moisture come into or contacted the LCD module, because the moisture may damage LCD module when it is operating.
- (3) It may reduce the display quality if the ambient temperature is lower than 10 °C. For example, the response time will become slowly, and the starting voltage of lamp will be higher than the room temperature.

OPERATION PRECAUTIONS

- (1) Do not pull the I/F connector in or out while the module is operating.
- (2) Always follow the correct power on/off sequence when LCD module is connecting and operating. This can prevent the CMOS LSI chips from damage during latch-up.