



LITEMAX AU1041

Sunlight Readable 10.4" LCD Display

(1st Edition 8/23/2007)

All information is subject to change without notice.

Approved by	Checked by	Prepared by
David	Sharline	River

LITEMAX Electronics Inc.
8F-2, No.133, Lane 235, Bau-chiau Rd.,
Shin-dian City, Taipei County, Taiwan R.O.C.
Tel : 886-2-8919-1858
Fax: 886-2-8919-1300
Homepage: <http://www.litemax.com.tw>

Record Revision

Version and Date	Page	Old Description	New Description	Remark

Contents

Record Revision	2
Contents	3
Handling Precautions	4
General Description	5
OUTLINE	5
STRUCTURE AND PRINCIPLE	5
APPLICATIONS	5
FEATURES	5
Physical specifications	6
Electrical specifications	7
Pin assignment	7
Electrical characteristics	9
Optical specifications (Note 1, Note 2)	14
Reliability test items (Tentative)	16

Handling Precautions

- 1) Since front polarizer is easily damaged, be extremely careful when handling panel.
- 2) Be sure to turn off power supply when inserting or disconnecting from input connectors.
- 3) Wipe off water immediately. Long contact with water may cause discoloration or spots.
- 4) When the panel surface is soiled, wipe it with absorbent cotton or other soft cloth.
- 5) Since the panel is made of glass, it may break or crack if dropped or bumped on a hard surface.
- 6) Since CMOS LSI is used in this module, be careful of static electricity by grounding those handling the display.
- 7) Do not open nor modify the module assembly.
- 8) Do not press or touch the panel surface with hands or tools.
- 9) Do not press or move the reflector sheet at the back of the module in any direction.
- 10) In case the module has to be put back into the packing container slot from where it was taken, do not press the center of the CCFL reflector edge. Instead, press at the far ends of the CCFL reflector edge softly. Otherwise the TFT module may be damaged.
- 11) **At the insertion or removal of the signal Interface Connector, be sure not to rotate nor tilt the interface connector of the TFT module.
- 12) After installation of the TFT module into an enclosure (Desktop monitor Bezel, for example), do not twist nor bend the TFT Module even momentarily. Design the enclosure so that no bending/twisting forces are applied to the TFT module. Otherwise the TFT module may be damaged.

General Description

This is a product specification that specifies form, fit, and function of the 10.4" TFT LCD monitor and its options. The AU1041 products are a family of high bright LCD monitors intended for use in a variety of industrial and commercial applications. Some of these applications include Car TV, Kiosk, Control Panel, Fish Finder, Marine, POI, Teketing, Aviation, Advertising, Gas Pumps, Signage... The LCD panel for AU1041 has a particularly fast response time of 35ms and consequently very well suited for video applications. The AU1041 is a 10.4" active matrix TFT LCD with a native resolution of 800X600 (SVGA). It has a typical luminance of 1500 nits with a +12VDC input. The video interface is through a standard 15 pin analog input with an integrated On-Screen Display (OSD).

OUTLINE

STRUCTURE AND PRINCIPLE

AU1041 module is composed of the driver LSIs for driving the TFT (Thin Film Transistor) array with an amorphous silicon thin film transistor liquid crystal display (a-Si TFT LCD) panel structure and a backlight. The a-Si TFT LCD panel structure is injected liquid crystal material into the narrow gap between a TFT array glass substrate and a color filter glass substrate.

RGB (Red, Green, and Blue) data signals from a source system are modulated into a form suitable for active matrix addressing by the onboard signal processor and sent to the driver LSIs which in turn address the individual TFT cells.

Working as an electro-optical switch, each TFT cell regulates transmitted light from the backlight assembly when worked by the data source. Color images are created by regulating the amount of transmitted light through the array of red, green and blue dots.

APPLICATIONS

Car TV, Kiosk, Control Panel, Fish Finder, Marine, POI, Ticketing, Aviation, Advertising, Gas Pumps, Signage...

FEATURES

- wide viewing angle
- Fast response time
- High Contrast Ratio
- LVDS
- Wide color gamut
- Very hight brightness
- Sunlight Readable

Physical specifications

NO.	Item	Specification	Remark
1	Display resolution (pixel)	800(H)×600(V)	
2	Active area (mm)	211.2(H)×158.4(V)	
3	Screen size (inch)	10.4(Diagonal)	
4	Pixel pitch (mm)	0.264(H)×0.264(V)	
5	Color configuration	R. G. B. Vertical stripe	
6	Overall dimension (mm)	243.0(W)×184.0(H)×27.2(D) (typ.)	Note 1
7	Weight (g)	680 ±10	

Note 1: Refer to Fig. 1. & 2.

Electrical specifications

Pin assignment

(1) Input signal interface

	Symbol	Function	Etc.
1	V _{cc}	+3.3 V power supply	
2	V _{cc}	+3.3 V power supply	
3	GND	Ground	
4	GND	Ground	
5	RxIN0	LVDS receiver signal channel 0	
6	RxIN0+		
7	GND	Ground	
8	RxIN1	LVDS receiver signal channel 1	
9	RxIN1+		
10	GND	Ground	
11	RxIN2	LVDS receiver signal channel 2	
12	RxIN2+		
13	GND	Ground	
14	CKIN	LVDS receiver signal clock	
15	CKIN+		
16	GND	Ground	
17	NC	No Connection	
18	NC	No Connection	
19	GND	Ground	
20	GND	Ground	

CN1 (20P) connector: HRS DF 19K-20P-1H or compatible

(2) LVDS transmitter/receiver signal mapping

	Symbol	Function	
TxIN0	R0	Red data (LSB)	6 bit red display data
TxIN1	R1	Red data	
TxIN2	R2	Red data	
TxIN3	R3	Red data	
TxIN4	R4	Red data	
TxIN5	R5	Red data (MSB)	
TxIN6	G0	Green data (LSB)	6 bit green display data
TxIN7	G1	Green data	
TxIN8	G2	Green data	
TxIN9	G3	Green data	
TxIN10	G4	Green data	
TxIN11	G5	Green data (MSB)	
TxIN12	B0	Blue data (LSB)	6 bits blue display data
TxIN13	B1	Blue data	
TxIN14	B2	Blue data	
TxIN15	B3	Blue data	
TxIN16	B4	Blue data	
TxIN17	B5	Blue data (MSB)	
TxIN18	Hs	Horizontal sync.	
TxIN19	Vs	Vertical sync.	
TxIN20	DE	Data enable	
TxCLKIN	CLK	Clock	Dot clock

2. Absolute maximum ratings

(GND = 0 V)

Parameter	Symbol	Values		Unit	Remark
		Min.	Max.		
Power voltage	V _{CC}	-0.3	4	V _{DC}	At 25°C
Input signal voltage	V _{LH}	-0.3	V _{CC} +0.3	V _{DC}	At 25°C
Operating temperature	T _{OP}	0	+50	°C	Note 1
Storage temperature	T _{ST}	-20	+60	°C	Note 1

Note (1) The relative humidity must not exceed 90% non-condensing at temperatures of 40°C or less. At temperatures greater than 40°C, the wet bulb temperature must not exceed 39 °C. When operate at low temperatures, the brightness of CCFL will drop and the lifetime of CCFL will be reduced.

Note (2) The unit should not be exposed to corrosive chemicals.

Electrical characteristics

a. Typical operating conditions

Item	Symbol	Min.	Typ.	Max.	Unit	Remark	
Power supply voltage	Input voltage	V_{CC}	3.0	3.3	3.6	V	
	Current consumption	I_A	243.7	242	245.2	mArms	Note 1
		I_B	255.4	252.1	253.5	mArms	
	Inrush current	I_{RUSH}	-	-	1500	mApeak	Note 2
Internal logic	Low voltage	V_{IL}	0	-	$0.3 V_{CC}$		
	High voltage	V_{IH}	$0.7V_{CC}$	-	V_{CC}		
Power ripple voltage	V_{RP}	-	-	100	mVp-p		

Note (1) Effective value (mArms) at $V_{CC} = 3.3 V/25^{\circ}C$.

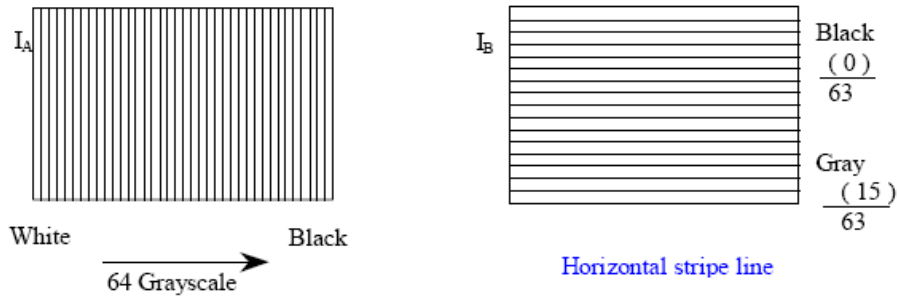

Note (2) Refer to the following power-on condition. White Black 64 Grayscale

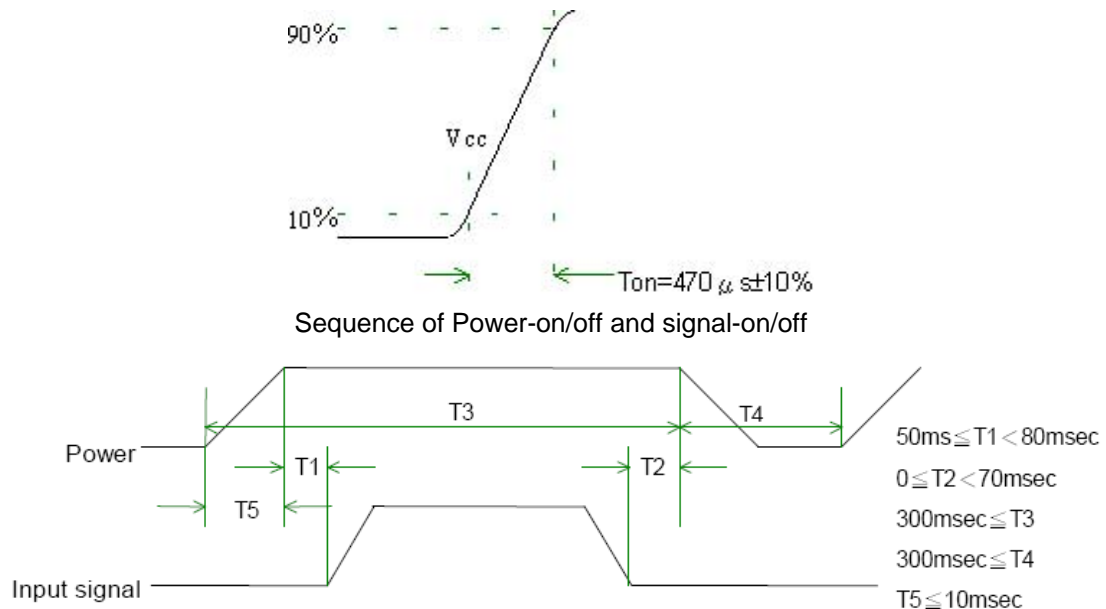

Apply the lamp voltage within the LCD operating range. When the backlight turns on before the LCD operation or the LCD turns off before the backlight turns off, the display may momentarily become abnormal.

Caution

The above on/off sequence should be applied to avoid abnormal function in the display. In case of handling: Make sure to turn off the power when you plug the cable into the input connector or pull the cable out of the connector.

b. Display color v.s. input data signals

Display colors		Data signal (0: Low level, 1: High level)																	
		R5	R4	R3	R2	R1	R0	G5	G4	G3	G2	G1	G0	B5	B4	B3	B2	B1	B0
Basic colors	Black	0	0	0	0	0	0	0	0	0	0	0	0	0	0	0	0	0	0
	Blue	0	0	0	0	0	0	0	0	0	0	0	0	1	1	1	1	1	1
	Red	1	1	1	1	1	1	0	0	0	0	0	0	0	0	0	0	0	0
	Magenta	1	1	1	1	1	1	0	0	0	0	0	0	1	1	1	1	1	1
	Green	0	0	0	0	0	0	1	1	1	1	1	1	0	0	0	0	0	0
	Cyan	0	0	0	0	0	0	1	1	1	1	1	1	1	1	1	1	1	1
	Yellow	1	1	1	1	1	1	1	1	1	1	1	1	0	0	0	0	0	0
	White	1	1	1	1	1	1	1	1	1	1	1	1	1	1	1	1	1	1
Red grayscale	Black	0	0	0	0	0	0	0	0	0	0	0	0	0	0	0	0	0	0
	Dark	0	0	0	0	1	0	0	0	0	0	0	0	0	0	0	0	0	0
	↕																		
	bright	1	1	1	1	0	1	0	0	0	0	0	0	0	0	0	0	0	0
	Red	1	1	1	1	1	1	0	0	0	0	0	0	0	0	0	0	0	0
Green grayscale	Black	0	0	0	0	0	0	0	0	0	0	0	0	0	0	0	0	0	0
	Dark	0	0	0	0	0	0	0	0	0	1	0	0	0	0	0	0	0	0
	↕																		
	bright	0	0	0	0	0	0	1	1	1	1	0	1	0	0	0	0	0	0
	Green	0	0	0	0	0	0	1	1	1	1	1	1	0	0	0	0	0	0
Blue grayscale	Black	0	0	0	0	0	0	0	0	0	0	0	0	0	0	0	0	0	0
	Dark	0	0	0	0	0	0	0	0	0	0	0	0	0	0	0	0	1	0
	↕																		
	bright	0	0	0	0	0	0	0	0	0	0	0	0	1	1	1	1	0	1
	Blue	0	0	0	0	0	0	0	0	0	0	0	0	1	1	1	1	1	1

Note: Each basic color can be displayed in 64 gray scales using the 6 bit data signals. By combining the 18-bit data signals(R, G, B), the 262,144 colors can be achieved on the display.

c. Input signal timing Timing diagrams of input signal are shown in Fig 2.

(1) Timing characteristics of input signals

(a) DE mode

(b) HV mode

Item	Symbol	Min.	Typ.	Max.	Unit	Remark
Clock frequency	Fck	38	40	48	MHz	
Horizontal blanking	Thb1	50	256	500	Clk	
Vertical blanking	Tvb1	10	28	150	Th	

Item	Symbol	Min.	Typ.	Max.	Unit	Remark
Clock frequency	Fck	38	40	48	MHz	
Hsync period	Th	850	1056	1300	Clk	
Hsync pulse width	Thw	10	128	-	Clk	
Hsync front porch	Thf	15	40	-	Clk	
Hsync back porch	Thb	10	88	-	Clk	
Hsync blanking	Thb1	50	256	500	Clk	
Vsync period	Tv	610	628	750	Th	
Vsync pulse width	Tvw	1	4	-	Th	
Vsync front porch	Tvf	0	1	-	Th	
Vsync blanking	Tvb1	10	28	150	Th	
Hsync/Vsync phase shift	Tvpd	2	320	-	Clk	

Item	Symbol	Value	Unit	Description
Horizontal display start	The	218	Clk	After falling edge of Hsync, counting 218clk, then getting valid data from 219 th clk's data.
Vertical display start	Tve	25	Th	After falling edge of Vsync, counting 25 th, then getting 26th Th's data.

(2) The timing condition of LVDS

Item	Symbol	Min.	Typ.	Max.	Unit
The differential level	$ V_{ID} $	0.1	-	0.6	V
The common mode input voltage	VIC	$ V_{ID} /2$	-	$2.4 - V_{ID} /2$	V
The input setup time	tsu1	500	-	-	ps
The input hold time	th1	500	-	-	ps

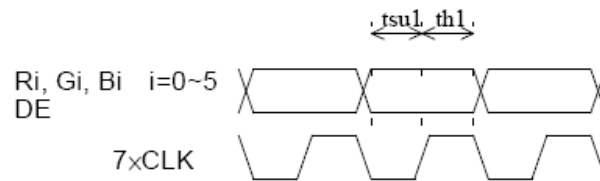
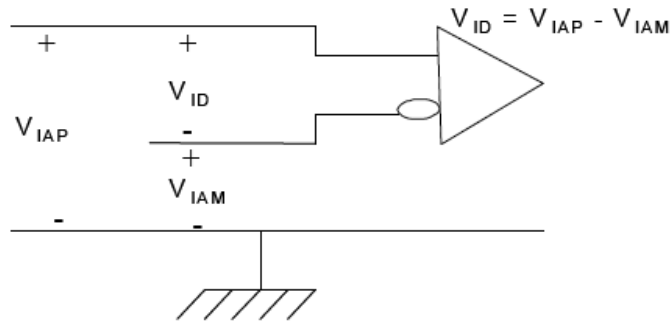

d. Display position

D(1,1)	D(2,1)	D(X,1)	D(799,1)	D(800,1)
D(1,2)	D(2,2)	D(X,2)	D(799,2)	D(800,2)
...	
D(1,Y)	D(2,Y)	D(X,Y)	D(799,Y)	D(800,Y)
...	
D(1,599)	D(2,599)	D(X,599)	D(799,599)	D(800,599)
D(1,600)	D(2,600)	D(X,600)	D(799,600)	D(800,600)

e. Backlight driving conditions

Parameter	Symbol	Min.	Typ.	Max.	Unit	Remark
Lamp voltage	V _L	-	420	-	Vrms	Note 1
Lamp current	I _L	33	36	39	mArms	Note 1
Power consumption	P _L	-	15.12	-	W	Note 2
Lamp starting voltage	V _s	-	-	-	Vrms	T=0°C
		-	1700	-		T=25°C
Frequency	F _L	50	55	60	KHz	Note 3
Lamp life time	L _L	-	50,000	-	Hr	Note 1, 4

Note (1) T= 25°C, I_L= 6mA/Lamp (Total 6 lamps)

Note (2) Inverter should be designed with the characteristic of lamp. When you are designing the inverter, the output voltage of the inverter should comply with the following conditions.

- The area under the positive and negative cycles of the waveform of the lamp current and lamp voltage should be area symmetric (the symmetric ratio should be larger than 90%).
- There should not be any spikes in the waveform.
- The waveform should be sine wave as possible.
- Lamp current should not exceed the maximum value within the operating Temperature (It is prohibited to over the maximum lamp current even if operated in The non-guaranteed temperature). When lamp current over the maximum value for a long time, it may cause fire. Therefore, it is recommend that the inverter should have the current limited circuit.

Note (3) Lamp frequency may produce interference with horizontal synchronous frequency and this may cause line flow on the display. Therefore lamp frequency shall be detached from the horizontal synchronous frequency and its harmonics as far as possible in order to avoid interference.

Note (4) Brightness (I_L=6mA/Lamp) to be decrease to the 50% of the initial value.

Note (5) CN2~4 connector (backlight): JST BHR-03VS-1

Pin no.	Symbol	Function	Remark
1	H	CCFL power supply (H.V.)	Cable color: Pink
2	H	CCFL power supply (H.V.)	Cable color: Pink

Mating connector: JST SM03(4.0)B-BHS-1-TB CN5 connector (backlight): JST

BHSR-02VS-1

Pin no.	Symbol	Function	Remark
1	L	CCFL power supply (GND)	Cable color: White
2	L	CCFL power supply (GND)	Cable color: Pink

Mating connector: JST SM02B-BHSS-1-TB

Optical specifications (Note 1, Note 2)

Item	Symbol	Condition	Specification			Unit	Remark
			Min.	Typ.	Max.		
Response time Rising time Falling time	Tr Tf	$\theta = 0^\circ$	--	10 25	20 30	ms	Note 4
Contrast ratio	CR	$\theta = 0^\circ$	400	500	-		Note 3,5
Viewing angle Top Bottom Left Right		$CR \geq 10$	----	40 60 60 60	----	deg.	Note 3,6
Brightness	Y_L	$\theta = 0^\circ$	1200	1500	-	nit	Note 3,7,8,9
Color chromaticity(CIE)	W_x	$\theta = 0^\circ$	0.290	0.320	0.350		Note 3,8,9
	W_y		0.300	0.330	0.360		
	R_x		TBD	TBD	TBD		
	R_y		TBD	TBD	TBD		
	G_x		TBD	TBD	TBD		
	G_y		TBD	TBD	TBD		
	B_x		TBD	TBD	TBD		
	B_y		TBD	TBD	TBD		
White uniformity	δw		-	-	1.3		Note 3,9,10

Note (1) Ambient temperature = 25°C.

Note (2) To be measured in dark room after backlight warm up 30 minutes.

Note (3) To be measured with a viewing cone of 1° by Topcon luminance meter BM-5A.

Note (4) Definition of response time: The output signals of BM-7 are measured when the input signals are changed from "Black" to "White" (falling time) and from "White" to "Black" (rising time), respectively. The response time means the interval between the 10% and 90% of amplitudes. Refer to figure as below.

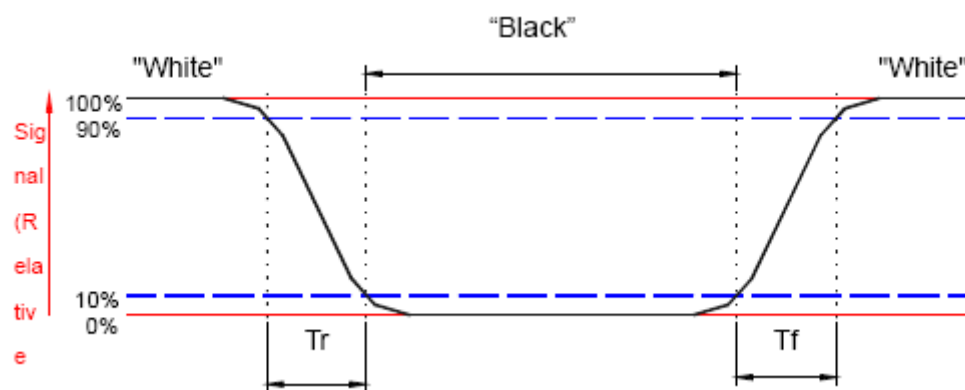

Note (5) Definition of contrast ratio:
 Contrast ratio is calculated with the following formula.

$$\text{Contrast ratio (CR)} = \frac{\text{Luminance on the white raster}}{\text{Luminance on the black raster}}$$

Note (6) Definition of viewing angle:

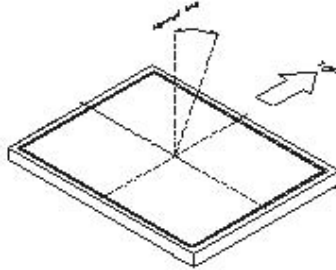

Note (7) Definition of the 5 points (from A to E) on panel, refer to figure as below

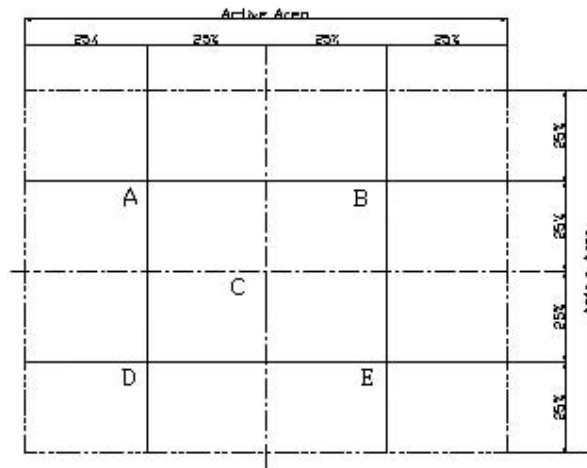

Note (8) Definition of brightness: To measure at center point of the screen (C)
 (After light up 20 minutes)

Note (9) Driving conditions for CCFL: $I_L=6$ mA, 55KHz Frequency

Note (10) Definition of white uniformity:

$$\delta_w = \frac{\text{Maximum Luminance of five points (brightness)}}{\text{Minimum Luminance of five points (brightness)}}$$

Reliability test items (Tentative)

Test tem	Test Condition	Remark
High temperature storage	60°C, 240Hrs	Note 1, 2, 3
Low temperature storage	-20°C, 240Hrs	Note 1, 2, 3
High temperature & high humidity operation	40°C, 90%RH, 240Hrs (No condensation)	Note 1, 2, 3
High temperature operation	50°C, 240Hrs	Note 1, 2, 3
Low temperature operation	0°C, 240Hrs	Note 1, 2, 3
Electrostatic discharge (non-operation)	150 pF, 150Ω, 10kV, 1 second, 9 position on the panel, 10 times each place	Note 3
Vibration (non-operation)	1.5G, 10Hz ~ 200Hz ~ 10Hz 30 minutes for each Axis (X, Y, Z)	Note 1, 2, 3
Mechanical shock (non-operation)	50G/20ms, ±X, ±Y, ±Z half-Sin, one time	Note 1, 2, 3
Thermal shock (non-operation)	1. -20°C±3°C...30minutes 60°C±3°C...30minutes 2. 100 cycles 3. Temperature transition time within 5 minutes	Note 1, 2, 3

Note (1) Evaluation should be tested after storage at room temperature for one hour.

Note (2) There should be no change which might affect the practical display function when the display quality test is conducted under normal operating condition.

Note (3) Judgement:

1. Function OK
2. No serious image quality degradation

