

- CONTENTS -

1. GENERAL DESCRIPTION	-----	2
1.1 OVERVIEW		
1.2 FEATURES		
1.3 APPLICATION		
1.4 GENERAL SPECIFICATIONS		
1.5 MECHANICAL SPECIFICATIONS		
2. ABSOLUTE MAXIMUM RATINGS	-----	5
2.1 ABSOLUTE RATINGS OF ENVIRONMENT		
2.2 ELECTRICAL ABSOLUTE RATINGS		
2.2.1 TFT LCD MODULE		
3. BLOCK DIAGRAM	-----	7
3.1 TFT LCD MODULE		
3.2 BACKLIGHT UNIT		
4. INPUT TERMINAL PIN ASSIGNMENT	-----	8
4.1 TFT LCD MODULE		
4.2 BACKLIGHT UNIT		
4.3 TIMING DIAGRAM OF LVDS INPUT SIGNAL		
4.4 COLOR DATA INPUT ASSIGNMENT		
5. INTERFACE TIMING	-----	10
5.1 INPUT SIGNAL TIMING SPECIFICATIONS		
5.2 POWER ON/OFF SEQUENCE		
6. OPTICAL CHARACTERISTICS	-----	12
6.1 TEST CONDITIONS		
6.2 OPTICAL SPECIFICATIONS		
7. PRECAUTIONS	-----	16
7.1 ASSEMBLY AND HANDLING PRECAUTIONS		
7.2 SAFETY PRECAUTIONS		
8. MECHANICAL CHARACTERISTICS	-----	17
9.LED Driving Board		

1. GENERAL DESCRIPTION

1.1 OVERVIEW

The CM1246E model is a 12.1" TFT-LCD module with a LED Backlight Unit and a 20-pin 1ch-LVDS interface. This module supports 800 x 600 SVGA mode and displays 262,144 colors. The inverter module for the Backlight Unit is LID12.

1.2 FEATURES

- Wide viewing angle
- High contrast ratio
- Fast response time
- High color saturation
- SVGA (800 x 600 pixels) resolution
- Wide operating temperature
- DE (Data Enable) mode
- LVDS (Low Voltage Differential Signaling) interface
- RoHS Compliance
- Reversible- Scan Function

1.3 APPLICATION

- Transportation
- Factory application
- Military
- Aviation
- Vehicle

1.4 GENERAL SPECIFICATIONS

Item	Specification	Unit	Note
Diagonal Size	12.1	inch	(1)
Active Area	246.00(H) x 184.50(V)	mm	
Bezel Opening Area	249.00(H) x 187.50(V)	mm	
Driver Element	a-si TFT active matrix	-	-
Pixel Number	800 x R.G.B. x 600	pixel	-
Pixel Pitch	0.3075(H) x 0.3075(V)	mm	-
Pixel Arrangement	RGB vertical stripe	-	-
Display Colors	262,144	color	-
Transmissive Mode	Normally black	-	-
Surface Treatment	Hard coating (3H), Anti-glare (Haze 25%)	-	-

1.5 MECHANICAL SPECIFICATIONS

Item		Min.	Typ.	Max.	Unit	Note
Module Size	Horizontal (H)	-	272	-	mm	(1)
	Vertical (V)	204	204.6	205	mm	
	Depth (D)	-	13.3	-	mm	
Weight		-	-	660	g	-
I/F connector mounting position		The mounting inclination of the connector makes the screen center within $\pm 0.5\text{mm}$ as the horizontal.			-	(2)

Note (1) Please refer to the attached drawings for more information of front and back outline dimensions.

(2) Connector mounting position

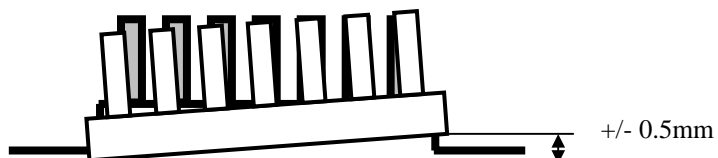

2. ABSOLUTE MAXIMUM RATINGS

2.1 ABSOLUTE RATINGS OF ENVIRONMENT

Item	Symbol	Value		Unit	Note
		Min.	Max.		
Operating Ambient Temperature	T _{OP}	-20	+60	°C	(0), (1), (2)
Storage Temperature	T _{ST}	-30	+70	°C	(0), (1)

Test Item	Test Condition	Note
High Temperature Storage Test	80°C, 240 hours	(1) (2)
Low Temperature Storage Test	-40°C, 240 hours	
Thermal Shock Storage Test	-40°C, 0.5hour 80 , 0.5hour; 100cycles, 1hour/cycle	
High Temperature Operation Test	60°C, 240 hours	
Low Temperature Operation Test	-20°C, 240 hours	
High Temperature & High Humidity Operation Test	60°C, RH 90%, 240hours	
Heat Cycle Operation Test	-20°C, 1hour 60°C, 1hour; 50cycles, 4hour/cycle	
ESD Test (Operation)	150pF, 330 , 1sec/cycle Condition 1 : panel contact, ±8KV Condition 2 : panel non-contact ±15KV	(2)
Shock (Non-Operating)	200G, 2ms, half sine wave, 1 time for ± X, ± Y, ± Z.	(2)(3)
Vibration (Non-Operating)	3.5G, 5 ~ 500 Hz, 60min/cycle, 3 cycles each X, Y, Z	2)(3)

Note (0) All test conditions are as above table.

Note (1) Temperature and relative humidity range is shown in the figure below.

(a) 90 %RH Max. (Ta ≤ 40 °C).

(b) Wet-bulb temperature should be 39 °C Max. (Ta > 40 °C).

(c) No condensation.

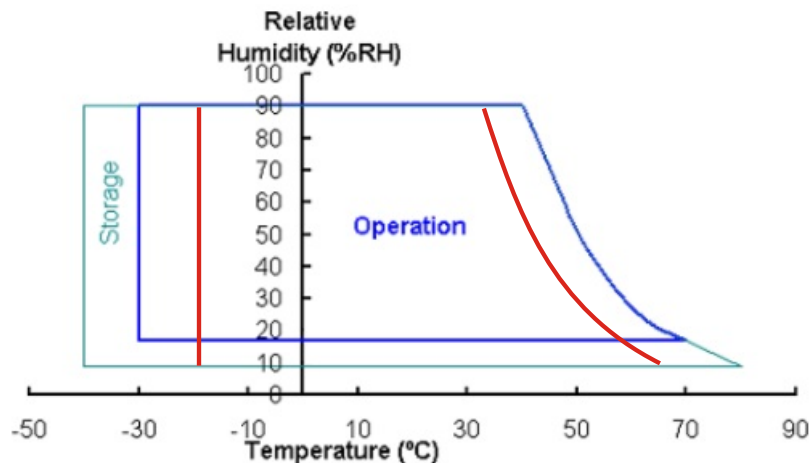

Note (2) No display malfunctions.

Note (3) At testing Vibration and Shock, the fixture in holding the module has to be hard and rigid enough so that the module would not be twisted or bent by the fixture.

Note (4) Temperature of panel display surface area should be 80 °C Max.

2.2 ELECTRICAL ABSOLUTE RATINGS

2.2.1 TFT LCD MODULE

Item	Symbol	Value		Unit	Note
		Min.	Max.		
Power Supply Voltage	V _{CC}	-0.3	6.0	V	(1)
Logic Input Voltage	V _{IN}	-0.3	2.7	V	

3. BLOCK DIAGRAM

3.1 TFT LCD MODULE

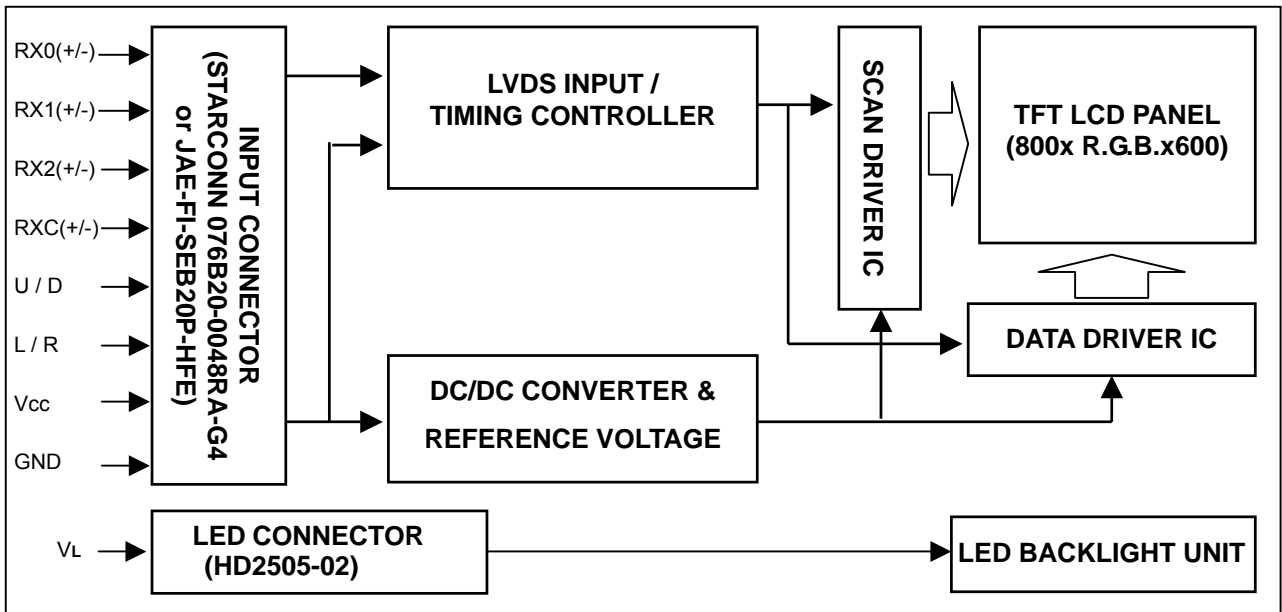

3.2 BACKLIGHT UNIT

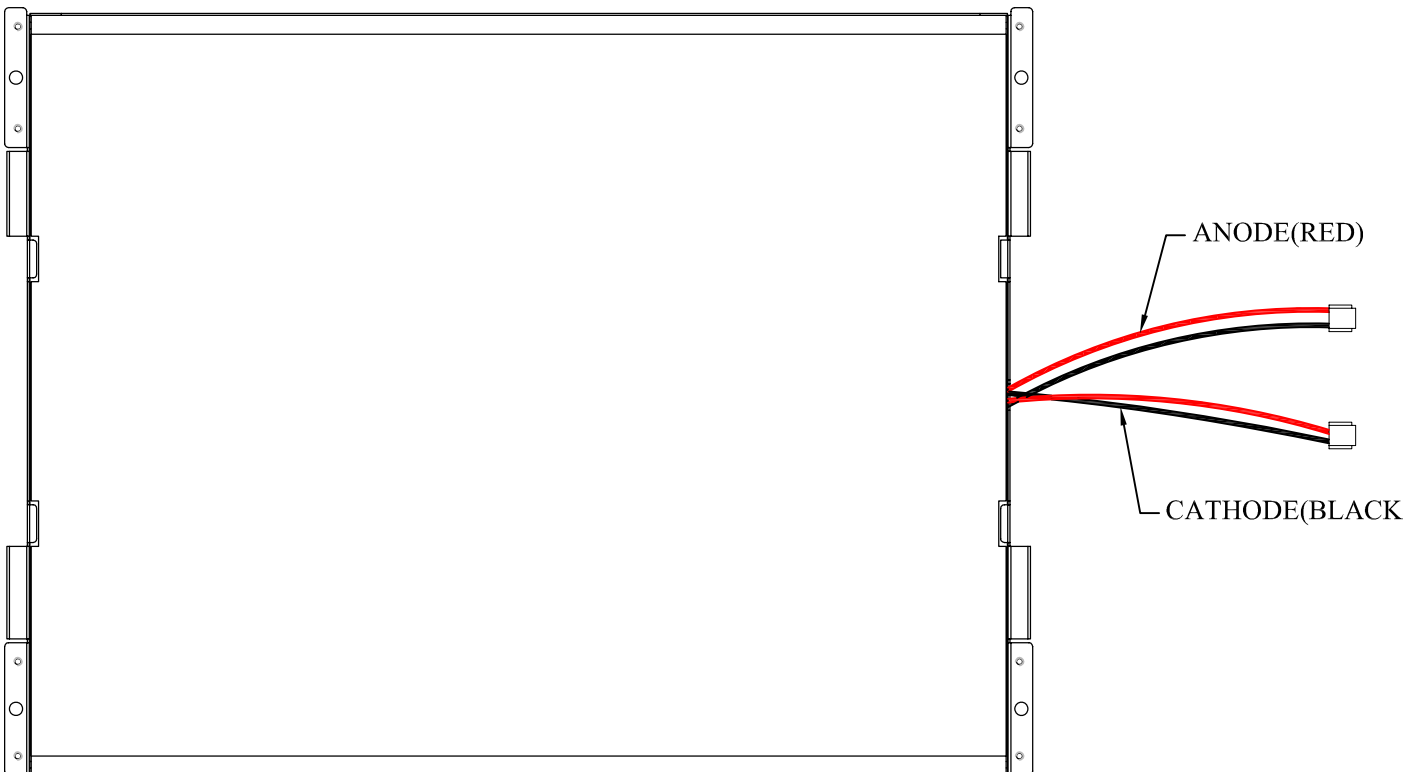

4. INPUT TERMINAL PIN ASSIGNMENT

4.1 TFT LCD MODULE

Pin	Name	Description	Remark
1	VCC_IN	Power Supply (5.0 V / 3.3 V)	
2	VCC_IN	Power Supply (5.0 V / 3.3 V)	
3	GND	Ground	
4	GND	Ground	
5	RX0-	Differential Data Input, CH0 (Negative)	R0 ~ R5, G0
6	RX0+	Differential Data Input, CH0 (Positive)	
7	GND	Ground	
8	RX1-	Differential Data Input, CH1 (Negative)	G1 ~ G5, B0, B1
9	RX1+	Differential Data Input , CH1 (Positive)	
10	GND	Ground	
11	RX2-	Differential Data Input , CH2 (Negative)	B2 ~ B5, DE
12	RX2+	Differential Data Input , CH2 (Positive)	
13	GND	Ground	
14	CLK-	Differential Clock Input (Negative)	LVDS Level Clock
15	CLK+	Differential Clock Input (Positive)	
16	GND	Ground	
17	L/R	Horizontal Display Mode Select Signal	Note (5)
18	U/D	Vertical Display Mode Select Signal	Note (5)
19	GND	Ground	
20	GND	Ground	

Note (1) Connector Part No.: STARCONN 076B20-0048RA-G4 or JAE FI-SEB20P-HFE or equivalent.

Note (2) Mating Connector Part No.: JAE-FI-SE20M, FI-S20S or equivalent.

Note (3) The first pixel is odd.

Note (4) Input signal of even and odd clock should be the same timing.

Note (5)

L/R=High, U/D=Low

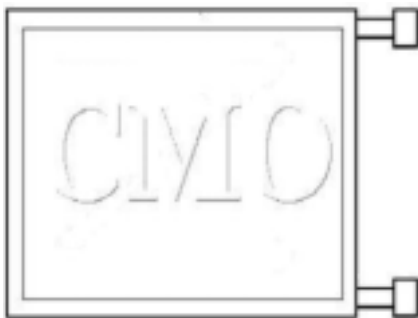

L/R=Low, U/D=Low



R/L=High, U/D=High



R/L=Low, U/D=High



4.2 BACKLIGHT UNIT

Pin	Symbol	Description	Remark
1	power	High Voltage	Red
2	GND	Low Voltage	Black

Note (1) Connector Part No.: HD2505-02 or equivalent

Note (2) User's connector Part No.: TD2505-02 or equivalent

4.3 COLOR DATA INPUT ASSIGNMENT

The brightness of each primary color (red, green and blue) is based on the 6-bit gray scale data input for the color. The higher the binary input, the brighter the color. The table below provides the assignment of color versus data input.

Color		Data Signal																	
		Red						Green						Blue					
		R5	R4	R3	R2	R1	R0	G5	G4	G3	G2	G1	G0	B5	B4	B3	B2	B1	B0
Basic Colors	Black	0	0	0	0	0	0	0	0	0	0	0	0	0	0	0	0	0	0
	Red	1	1	1	1	1	1	0	0	0	0	0	0	0	0	0	0	0	0
	Green	0	0	0	0	0	0	1	1	1	1	1	1	0	0	0	0	0	0
	Blue	0	0	0	0	0	0	0	0	0	0	0	0	1	1	1	1	1	1
	Cyan	0	0	0	0	0	0	1	1	1	1	1	1	1	1	1	1	1	1
	Magenta	1	1	1	1	1	1	0	0	0	0	0	0	1	1	1	1	1	1
	Yellow	1	1	1	1	1	1	1	1	1	1	1	1	0	0	0	0	0	0
	White	1	1	1	1	1	1	1	1	1	1	1	1	1	1	1	1	1	1
Gray Scale Of Red	Red(0)/Dark	0	0	0	0	0	0	0	0	0	0	0	0	0	0	0	0	0	0
	Red(1)	0	0	0	0	0	1	0	0	0	0	0	0	0	0	0	0	0	0
	Red(2)	0	0	0	0	1	0	0	0	0	0	0	0	0	0	0	0	0	0
	:	:	:	:	:	:	:	:	:	:	:	:	:	:	:	:	:	:	:
	:	:	:	:	:	:	:	:	:	:	:	:	:	:	:	:	:	:	:
	:	:	:	:	:	:	:	:	:	:	:	:	:	:	:	:	:	:	:
	Red(61)	1	1	1	1	0	1	0	0	0	0	0	0	0	0	0	0	0	0
	Red(62)	1	1	1	1	1	0	0	0	0	0	0	0	0	0	0	0	0	0
Red(63)	1	1	1	1	1	1	0	0	0	0	0	0	0	0	0	0	0	0	
Gray Scale Of Green	Green(0)/Dark	0	0	0	0	0	0	0	0	0	0	0	0	0	0	0	0	0	0
	Green(1)	0	0	0	0	0	0	0	0	0	0	0	1	0	0	0	0	0	0
	Green(2)	0	0	0	0	0	0	0	0	0	0	1	0	0	0	0	0	0	0
	:	:	:	:	:	:	:	:	:	:	:	:	:	:	:	:	:	:	:
	:	:	:	:	:	:	:	:	:	:	:	:	:	:	:	:	:	:	:
	:	:	:	:	:	:	:	:	:	:	:	:	:	:	:	:	:	:	:
	Green(61)	0	0	0	0	0	0	1	1	1	1	0	1	0	0	0	0	0	0
	Green(62)	0	0	0	0	0	0	1	1	1	1	1	0	0	0	0	0	0	0
Green(63)	0	0	0	0	0	0	1	1	1	1	1	1	0	0	0	0	0	0	
Gray Scale Of Blue	Blue(0)/Dark	0	0	0	0	0	0	0	0	0	0	0	0	0	0	0	0	0	0
	Blue(1)	0	0	0	0	0	0	0	0	0	0	0	0	0	0	0	0	0	1
	Blue(2)	0	0	0	0	0	0	0	0	0	0	0	0	0	0	0	0	1	0
	:	:	:	:	:	:	:	:	:	:	:	:	:	:	:	:	:	:	:
	:	:	:	:	:	:	:	:	:	:	:	:	:	:	:	:	:	:	:
	:	:	:	:	:	:	:	:	:	:	:	:	:	:	:	:	:	:	:
	Blue(61)	0	0	0	0	0	0	0	0	0	0	0	0	1	1	1	1	0	1
	Blue(62)	0	0	0	0	0	0	0	0	0	0	0	0	1	1	1	1	1	0
Blue(63)	0	0	0	0	0	0	0	0	0	0	0	0	1	1	1	1	1	1	

Note (1) 0: Low Level Voltage, 1: High Level Voltage

5. INTERFACE TIMING

5.1 INPUT SIGNAL TIMING SPECIFICATIONS

The input signal timing specifications are shown as the following table and timing diagram.

Signal	Item	Symbol	Min.	Typ.	Max.	Unit	Note
LVDS Clock	Frequency	F_c	33.4	39.7	48.3	MHz	-
	Period	T_c	20.7	25.1	29.9	ns	-
Vertical Active Display Term	Frame Rate	F_r	56	60	75	Hz	$T_v = T_{vd} + T_{vb}$
	Total	T_v	606	628	650	Th	-
	Display	T_{vd}	600	600	600	Th	-
	Blank	T_{vb}	$T_v - T_{vd}$	28	$T_v - T_{vd}$	Th	-
Horizontal Active Display Term	Total	T_h	920	1056	1240	T_c	$T_h = T_{hd} + T_{hb}$
	Display	T_{hd}	800	800	800	T_c	-
	Blank	T_{hb}	$T_h - T_{hd}$	256	$T_h - T_{hd}$	T_c	-

Note : (1) Because this module is operated by DE only mode, Hsync and Vsync input signals should be set to low logic level or ground. Otherwise, this module would operate abnormally.

INPUT SIGNAL TIMING DIAGRAM

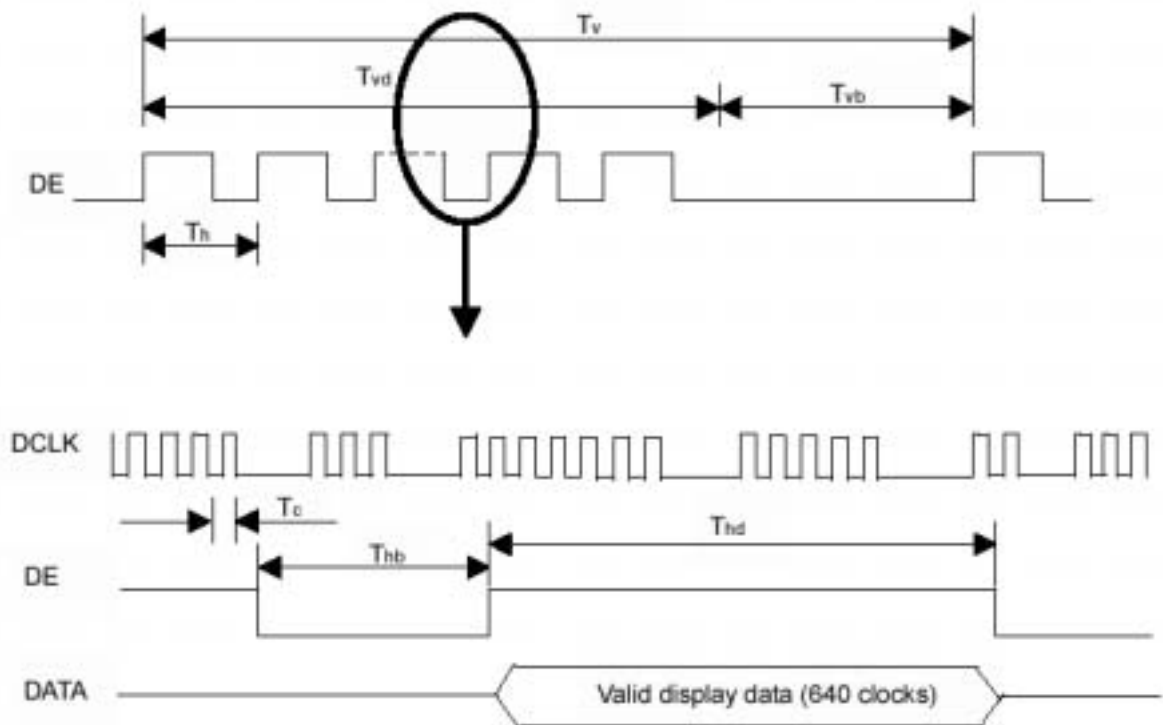

5.2 POWER ON/OFF SEQUENCE

To prevent a latch-up or DC operation of LCD module, the power on/off sequence should follow the conditions shown in the following diagram.

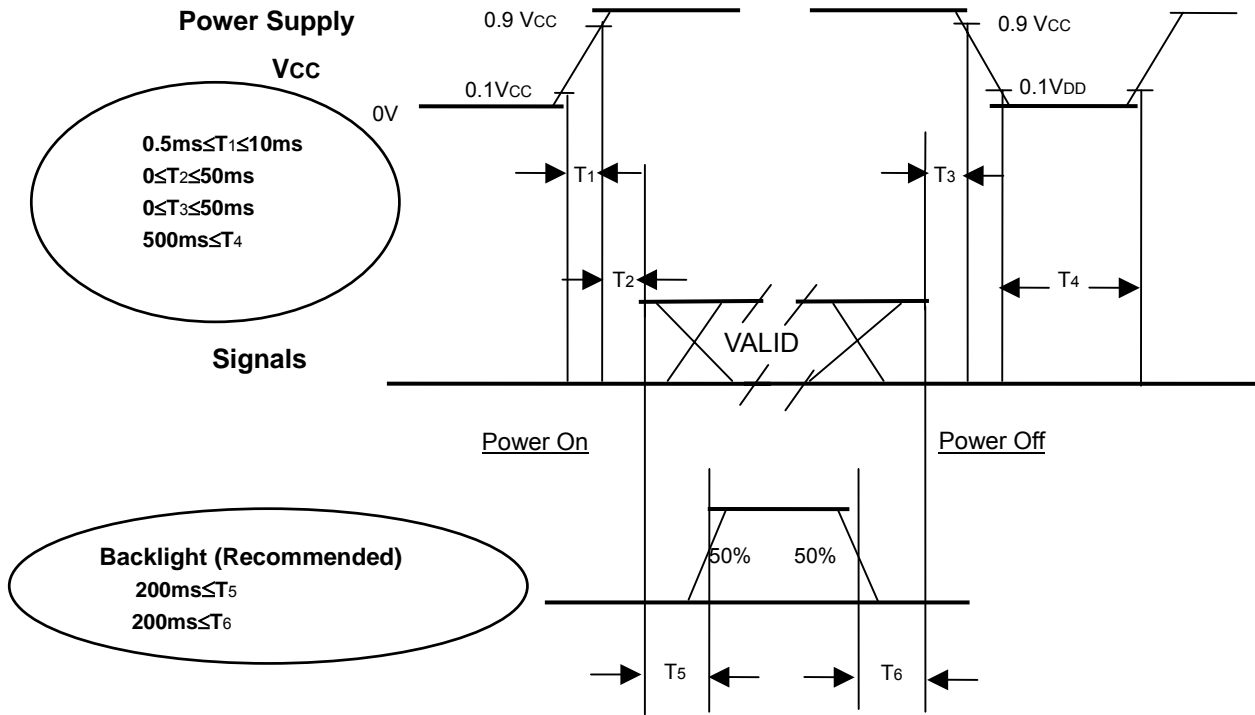

Power ON/OFF Sequence

Note (1) Please avoid floating state of interface signal at invalid period.

Note (2) When the interface signal is invalid, be sure to pull down the power supply of LCD Vcc to 0 V.

Note (3) The LED Backlight Driver power must be turned on after the power supply for the logic and the interface signal is valid. The LED Backlight Driver power must be turned off before the power supply for the logic and the interface signal is invalid.

6. OPTICAL CHARACTERISTICS

6.1 TEST CONDITIONS

Item	Symbol	Value	Unit
Ambient Temperature	Ta	25±2	°C
Ambient Humidity	Ha	50±10	%RH
Supply Voltage	V _{CC}	5.0	V
Input Signal	According to typical value in "3. ELECTRICAL CHARACTERISTICS"		
LED Driver	LID12		

6.2 OPTICAL SPECIFICATIONS

The relative measurement methods of optical characteristics are shown in 7.2. The following items should be measured under the test conditions described in 7.1 and stable environment shown in Note (5).

Item	Symbol	Condition	Min.	Typ.	Max.	Unit	Note				
Color Chromaticity	Red	Rx	-	0.603	-	-	(1), (5)				
		Ry		0.366		-					
	Green	Gx		0.35		-					
		Gy		0.542		-					
	Blue	Bx		0.147		-					
		By		0.122		-					
	White	Wx		0.326		-					
		Wy		0.340		-					
	Center Luminance of White	L _C				-		1000	-	cd/m ²	4), (5)
	Contrast Ratio	CR				-		1100	-	-	(2), (5)
Response Time	T _R	θ _x =0°, θ _y =0°	-	13	-	ms	(3)				
	T _F		-	12	-	ms					
White Variation	δW	θ _x =0°, θ _y =0°	-	1.25	-	-	(5), (6)				
Viewing Angle	Horizontal	θ _{x+}	CR≥10	-	70	-	Deg.	(1), (5)			
		θ _{x-}		-	70	-					
	Vertical	θ _{y+}		-	70	-					
		θ _{y-}		-	70	-					

Note (1) Definition of Viewing Angle (θ_x, θ_y):

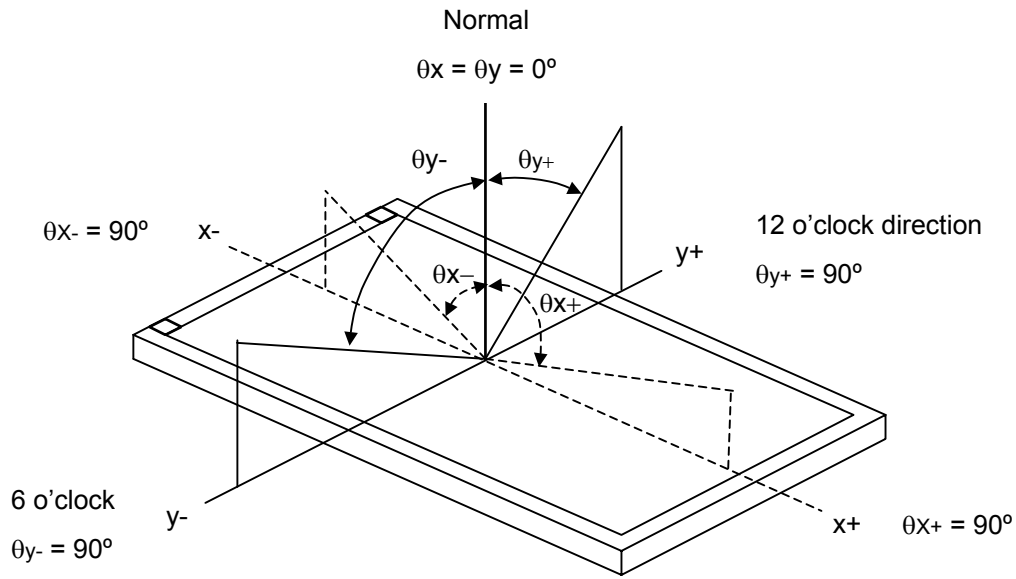

Note (2) Definition of Contrast Ratio (CR):

The contrast ratio can be calculated by the following expression.

$$\text{Contrast Ratio (CR)} = L_{63} / L_0$$

L63: Luminance of gray level 63

L 0: Luminance of gray level 0

$$CR = CR(5)$$

CR (X) is corresponding to the Contrast Ratio of the point X at Figure in Note (6).

Note (3) Definition of Response Time (T_R, T_F) and measurement method:

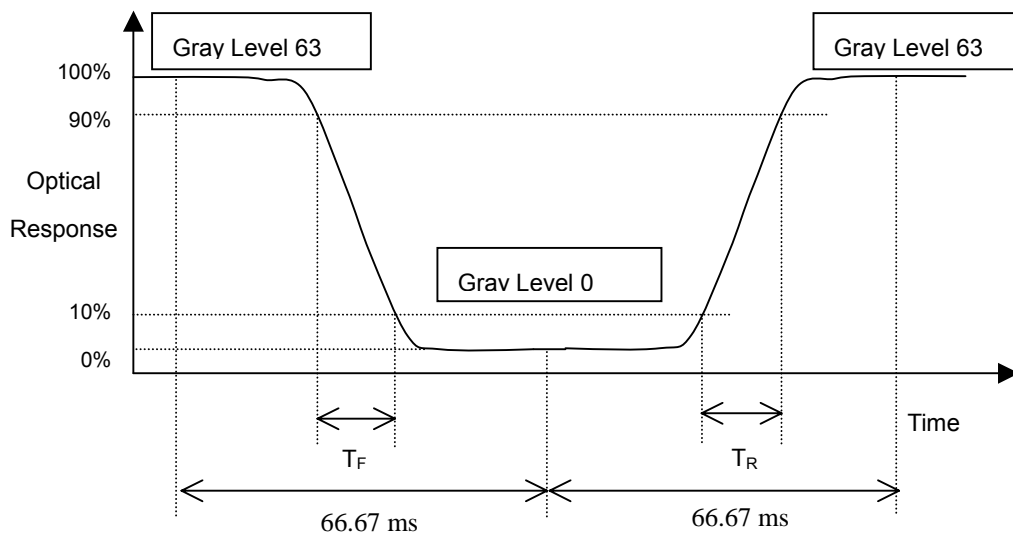

Note (4) Definition of Luminance of White (L_C):

Measure the luminance of gray level 63 at center point

$$L_C = L(5)$$

$L(x)$ is corresponding to the luminance of the point X at Figure in Note (6).

Note (5) Measurement Setup:

The LCD module should be stabilized at given temperature for 20 minutes to avoid abrupt temperature change during measuring. In order to stabilize the luminance, the measurement should be executed after lighting Backlight for 20 minutes in a windless room.

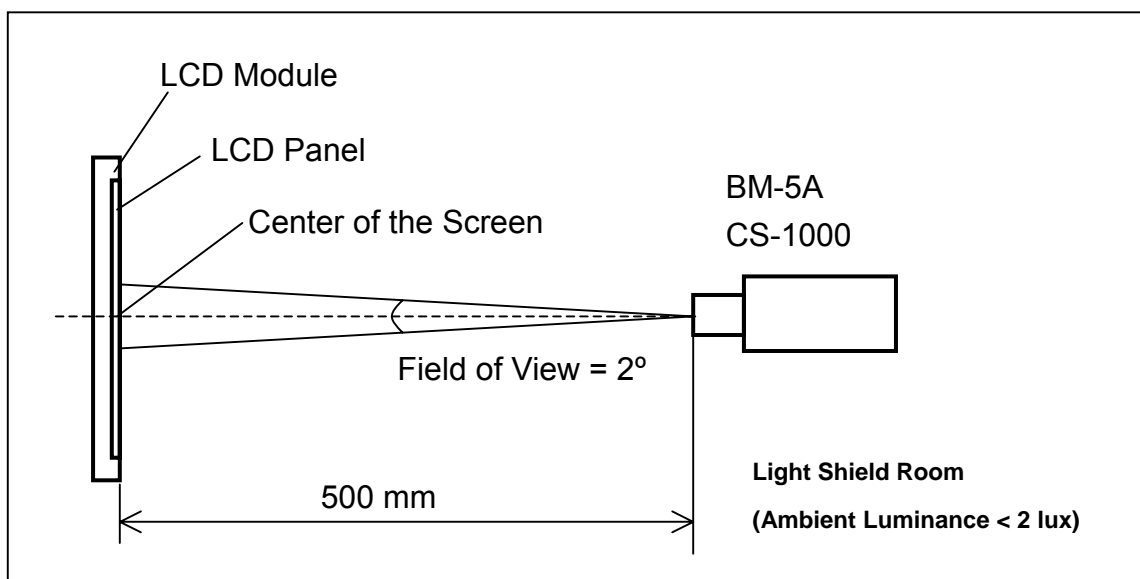

Note (6) Definition of White Variation (δW):

Measure the luminance of gray level 63 at 5 points

$$\delta W = \frac{\text{Maximum [L (1), L (2), L (3), L (4), L (5)]}}{\text{Minimum [L (1), L (2), L (3), L (4), L (5)]}}$$

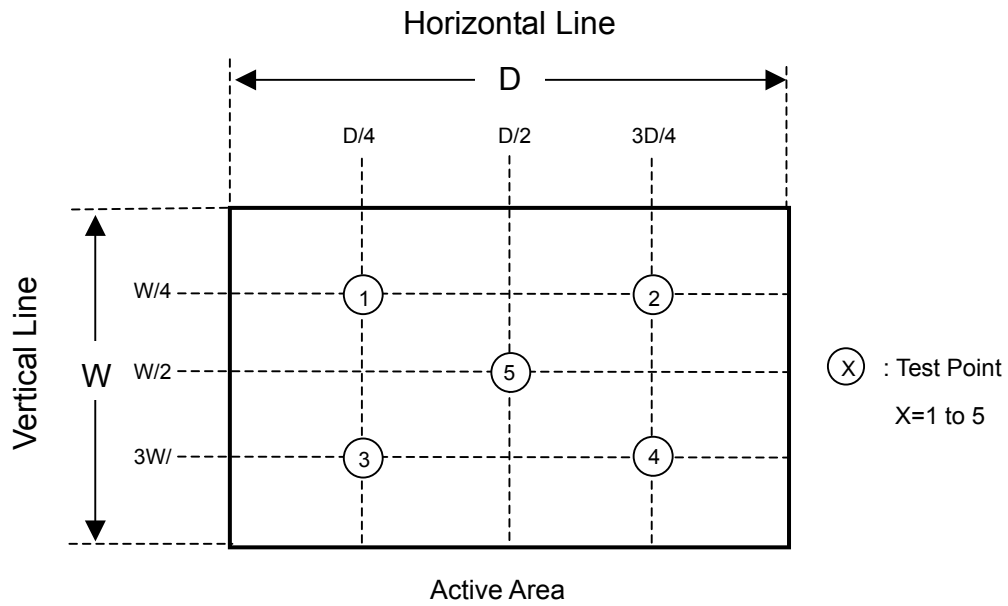

7. PRECAUTIONS

7.1 ASSEMBLY AND HANDLING PRECAUTIONS

- (1) Do not apply rough force such as bending or twisting to the module during assembly.
- (2) To assemble or install module into user's system can be only in clean working areas. The dust and oil may cause electrical short or worsen the polarizer.
- (3) It's not permitted to have pressure or impulse on the module because the LCD panel and Backlight will be damaged.
- (4) Always follow the correct power sequence when LCD module is connecting and operating. This can prevent damage to the CMOS LSI chips during latch-up.
- (5) Do not pull the I/F connector in or out while the module is operating.
- (6) Do not disassemble the module.
- (7) Use a soft dry cloth without chemicals for cleaning, because the surface of polarizer is very soft and easily scratched.
- (8) It is dangerous that moisture come into or contacted the LCD module, because moisture may damage LCD module when it is operating.
- (9) High temperature or humidity may reduce the performance of module. Please store LCD module within the specified storage conditions.

7.2 SAFETY PRECAUTIONS

- (1) If the liquid crystal material leaks from the panel, it should be kept away from the eyes or mouth. In case of contact with hands, skin or clothes, it has to be washed away thoroughly with soap.
- (2) After the module's end of life, it is not harmful in case of normal operation and storage.

