



LITEMAX

SSF/SSH8604-M

Sunlight Readable 86" LED B/L LCD

User Manual

Approved by	Checked by	Prepared by

LITEMAX Electronics Inc.
8F, No.137, Lane 235, Bau-chiau Rd.,
Shin-dian Dist., New Taipei City, Taiwan
R.O.C.
Tel : 886-2-8919-1858
Fax: 886-2-8919-1300
Homepage: <http://www.litemax.com>

Record of Revision

Version and Date	Page	Old Description	New Description	Remark
Mar./16/2026	all		Initial release	

Contents

Record of Revision	2
Contents	3
1 General Description.....	4
1.1 Key Features.....	4
1.2 General Specifications.....	4
1.3 Absolute Maximum Ratings.....	5
2 Electrical Specifications	6
2.1 Electrical Characteristics.....	6
2.2 Interface Connections.....	7
2.3 Signal Timing Specifications	10
2.4 V by One Signal Specifications.....	11
2.5 Intra Interface Signal Specification.....	12
2.6 Color Data Reference	13
2.7 Power Sequence	14
3 Optical Specification	15
4 LED Driving Board Specifications.....	17
4.1 Operating Characteristics	17
4.2 Connector Socket	17
4.3 Mechanical Characteristics	19
5 Mechanical Drawing	20
6 AD9800HP Board & OSD Functions	22
6.1 OSD Function.....	29
6.2 OSD Menu	30
7 Precautions.....	31
7.1 Handling and Mounting Precautions.....	31
7.2 Storage Precautions	31
7.3 Operation Precautions	32
8 Disclaimer.....	32

1 General Description

The **SSF/SSH8604-M** is a 86 inch color TFT-LCD display with special aspect ratio 16:2.5 and wide resolution 3840 x 600. It is Litemax's Spanpixel series product which designed for high brightness 700 nits with power efficiency LED backlight. It provides LCD panel with specific aspect ratios and sunlight readable for digital signage, public transportation, exhibition hall, department store, and vending machine.

1.1 Key Features

- Resizing LCD
- Ultra-Wide Screen (16:2.5)
- High Brightness 700 nits
- LED Backlight
- BL MTBF: 30,000 hours

1.2 General Specifications

Model Name	SSF/SSH8604-M
Description	86" Resizing LCD, 700 nits LED backlight, 3840x600, Ultra-Wide Screen
Screen Size	86"
Display Area (mm)	2158.85(H) x 337.32(V)
Brightness	700 cd/m2
Resolution	3840x600
Aspect Ratio	16:2.5
Contrast Ratio	1200:1
Pixel Pitch (mm)	0.5622(H) x 0.5622(V)
Pixel Per Inch (PPI)	45
Viewing Angle	178°(H),178°(V)
Color Saturation (NTSC)	82%
Display Colors	1.07G
Response Time (Typical)	8ms
Panel Interface	V-by-One
Input Interface	HDMI, DP
Input Power	AC100-240V
Power Consumption	148W (151W with AD board)
OSD Key	5 Keys (Power Switch, Menu, +, -, Exit)
OSD Control	Brightness, Color, Contrast, Auto Tuning, H/V Position...etc
Dimensions (mm)	2188.50(W) x 372.20(H) x 43.80(D)
Bezel Size(U/B/L/R)	17.94/16.94/14.83/14.83 mm
Weight (Net)	22Kg
Operating Temperature	0 °C ~ 50 °C
Storage Temperature	-20 °C ~ 60 °C

SSF= Panel + LED Driving Board

SSH= Panel + LED Driving Board + AD Control Board

1.3 Absolute Maximum Ratings

The followings are maximum values which, if exceeded, may cause faulty operation or permanent damage to the LCD module.

Parameter		Symbol	Value		Unit	Note
			Min	Max		
Power Input Voltage	LCD Circuit	V _{LCD}	-0.3	+14.0	V _{DC}	1
T-Con Option Selection Voltage		V _{LOGIC}	-0.3	+4.0	V _{DC}	
Operating Temperature		T _{OP}	0	+50	°C	2
Storage Temperature(without packing)		T _{ST}	-20	+60	°C	
Panel Front Temperature		T _P T	-	+68	°C	3
Operating Ambient Humidity		H _{OP}	10	90	%RH	2
Storage Humidity		H _{ST}	5	90	%RH	

Note 1. Ambient temperature condition ($T_a = 25 \pm 2 \text{ }^\circ\text{C}$)

2. Temperature and relative humidity range are shown in the figure below.

Wet bulb temperature should be Max 39°C, and no condensation of water.

3. The maximum operating temperatures is based on the test condition that the surface temperature of display area is less than or equal to 68°C with LCD module alone in a temperature controlled chamber. Thermal management should be considered in final product design to prevent the surface temperature of display area from being over 68°C. The range of operating temperature may be degraded in case of improper thermal management in final product design.

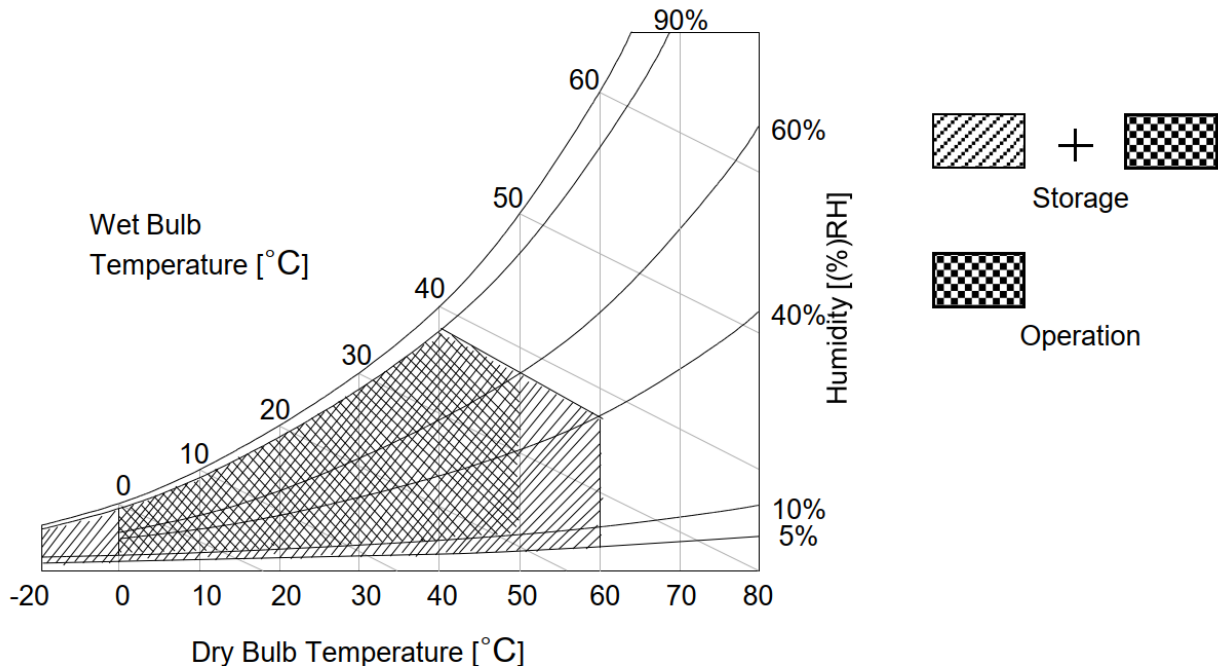

2 Electrical Specifications

2.1 Electrical Characteristics

Parameter	Symbol	Value			Unit	Note	
		Min	Typ	Max			
Circuit :							
Power Input Voltage	V _{LCD}	10.8	12.0	13.2	V _{dc}		
Power Input Current	I _{LCD}	-	745	969	mA	1	
		-	2480	3224	mA	2	
T-CON Option Selection Voltage	Input High Voltage	V _{IH}	2.7	-	3.6	V _{DC}	
	Input Low Voltage	V _{IL}	0	-	0.7	V _{DC}	
Power Consumption	P _{LCD}	-	8.94	11.62	Watt	1	
		-	29.76	38.68	Watt	2	
Rush current	I _{RUSH}	-	-	15	A	3	

- Note 1. The specified current and power consumption are under the V_{LCD}=12.0V, Ta=25 ± 2°C, f_V=60Hz condition, and mosaic pattern(8 x 6) is displayed and f_V is the frame frequency.
 2. The current is specified at the maximum current pattern.
 3. The duration of rush current is about 2ms and rising time of power input is 0.5ms (min.).
 4. Ripple voltage level is recommended under ±5% of typical voltage

White : 255 Gray
 Black : 0 Gray

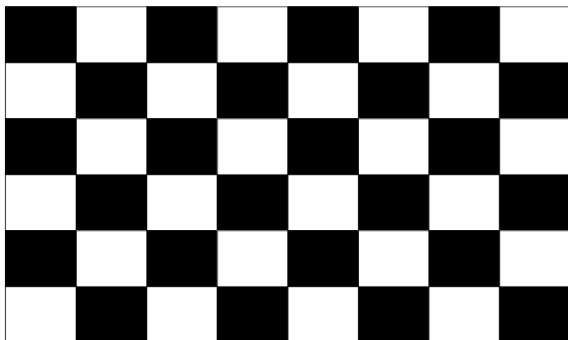

Mosaic Pattern(8 x 6)

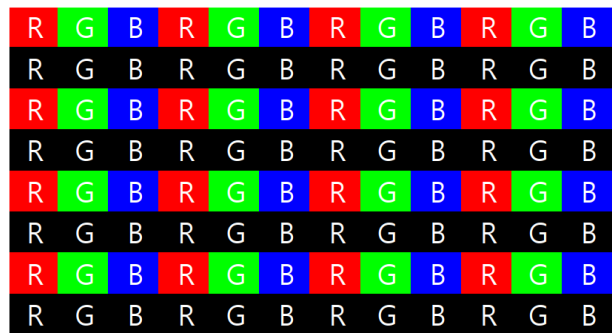

Max Current Pattern

2.2 Interface Connections

This LCD module employs three kinds of interface connection, 5 pin connector, 51pin connector are used for the module electronics.

LCD module

- LCD Connector (CN1): 20037WR-H05
- Mating Connector: SMH200 H05M or compatible

Module Connector (CN1) PIN Configuration

Pin No	Symbol	Description	Note
1	GND	Ground	
2	GND	Ground	
3	VLCD	Power Supply +12.0V	
4	VLCD	Power Supply +12.0V	
5	VLCD	Power Supply +12.0V	

-LCD Connector (CN1): FI-RXE51S-HF or compatible

-Mating Connector: FI-R51HL or compatible

Module Connector (CN2) PIN Configuration

No	Symbol	Description	No	Symbol	Description
1	NC	No Connection(Notes 2)	27	GND	Ground
2	NC	No Connection(Notes 2)	28	Rx0n	V-by-One HS Data Lane 0
3	NC	No Connection(Notes 2)	29	Rx0p	V-by-One HS Data Lane 0
4	NC	No Connection(Notes 2)	30	GND	Ground
5	NC	No Connection(Notes 2)	31	Rx1n	V-by-One HS Data Lane 1
6	NC	No Connection(Notes 2)	32	Rx1p	V-by-One HS Data Lane 1
7	NC	No Connection(Notes 2)	33	GND	Ground
8	NC	No Connection(Notes 2)	34	Rx2n	V-by-One HS Data Lane 2
9	NC	No Connection	35	Rx2p	V-by-One HS Data Lane 2
10	GND	Ground	36	GND	Ground
11	GND	Ground	37	Rx3n	V-by-One HS Data Lane 3
12	GND	Ground	38	Rx3p	V-by-One HS Data Lane 3
13	GND	Ground	39	GND	Ground
14	NC	NO CONNECTION	40	Rx4n	V-by-One HS Data Lane 4
15	NC	NO CONNECTION	41	Rx4p	V-by-One HS Data Lane 4
16	Data format	'L' : Non division, 'H' 2 division	42	GND	Ground
17	NC	NO CONNECTION	43	Rx5n	V-by-One HS Data Lane 5
18	NC	NO CONNECTION	44	Rx5p	V-by-One HS Data Lane 5
19	NC	NO CONNECTION	45	GND	Ground
20	NC	NO CONNECTION	46	Rx6n	V-by-One HS Data Lane 6
21	Bit_SEL	'H' = 10bit , 'L' = 8bit	47	Rx6p	V-by-One HS Data Lane 6
22	NC	NO CONNECTION	48	GND	Ground
23	RBF	'H' : AGP(Default), 'L' : NSB (No signal Black)	49	Rx7n	V-by-One HS Data Lane 7
24	NC	NO CONNECTION	50	Rx7p	V-by-One HS Data Lane 7
25	HTPDN	Hot plug detect	51	GND	Ground
26	LOCKN	Lock detect	-	-	-

Notes:

1. All GND (ground) pins should be connected together to the LCD module's metal frame.
2. All Input levels of V-by-One signals are based on the V-by-One HS Standard Version **1.4**.
3. #1~#9, #14~#15, #17~#20, #22, #24 NC (No Connection) : These pins are used only for LGD (Do not connect)
4. About specific pin (#16) , Please see the **Appendix V**.
5. Specific pin No. #23 is used for "No signal detection" of system signal interface.
It should be GND or NC for NSB (No Signal Black) while the system interface signal is not.
If this pin is "H" , LCD Module displays AGP (Auto Generation Pattern).

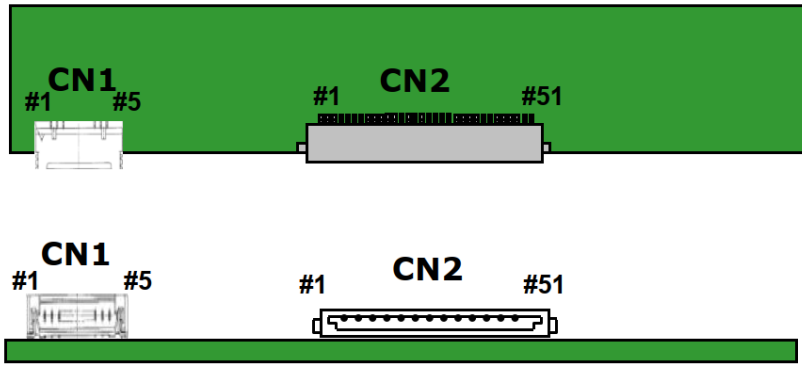

Rear view of LCM

APPENDIX-V

■ input mode of pixel data

Mode 1 : Non-Division				Mode 2 : 2 Division			
Lane	1 st Data	2 nd Data	Data#	Lane	1 st Data	2 nd Data	Data#
Lane0	1	9	3833	Lane0	1	5	1917
Lane1	2	10	3834	Lane1	2	6	1918
Lane2	3	11	3835	Lane2	3	7	1919
Lane3	4	12	3836	Lane3	4	8	1920
Lane4	5	13	3837	Lane4	1921	1925	3837
Lane5	6	14	3838	Lane5	1922	1926	3838
Lane6	7	15	3839	Lane6	1923	1927	3839
Lane7	8	16	3840	Lane7	1924	1928	3840

2.3 Signal Timing Specifications

The table shows the signal timing required at the input of the Vx1 transmitter. All of the interface signal timings

Timing Table (DE Only Mode)

ITEM		Symbol	Min	Typ	Max	Unit	Note
Horizontal	Display Period	t_{HV}	480	480	480	t_{CLK}	3840/8
	Blank	t_{HB}	60	70	120	t_{CLK}	1
	Total	t_{HP}	540	550	600	t_{CLK}	
Vertical	Display Period	t_{VV}	2160	2160	2160	Lines	
	Blank	t_{VB}	40	90	600	Lines	1
	Total	t_{VP}	2200	2250	2760	Lines	

ITEM		Symbol	Min	Typ	Max	Unit	Note
Frequency	DCLK	f_{CLK}	60	74.25	78.00	MHz	594/8
	Horizontal	f_H	121.8	135	140	KHz	2
	Vertical	f_V	47	60	63	Hz	2

Notes:

1. The input of HSYNC & VSYNC signal does not have an effect on normal operation (DE Only Mode).
If you use spread spectrum of EMI, add some additional clock to minimum value for clock margin.
2. The performance of the electro-optical characteristics may be influenced by variance of the vertical refresh rate and the horizontal frequency
3. Spread Spectrum Rate (SSR) is limited to $\pm 0.5\%$ center spread at 30KHz
※Timing should be set based on clock frequency.

2.4 V by One Signal Specifications

V by One input Signal Timing Diagram

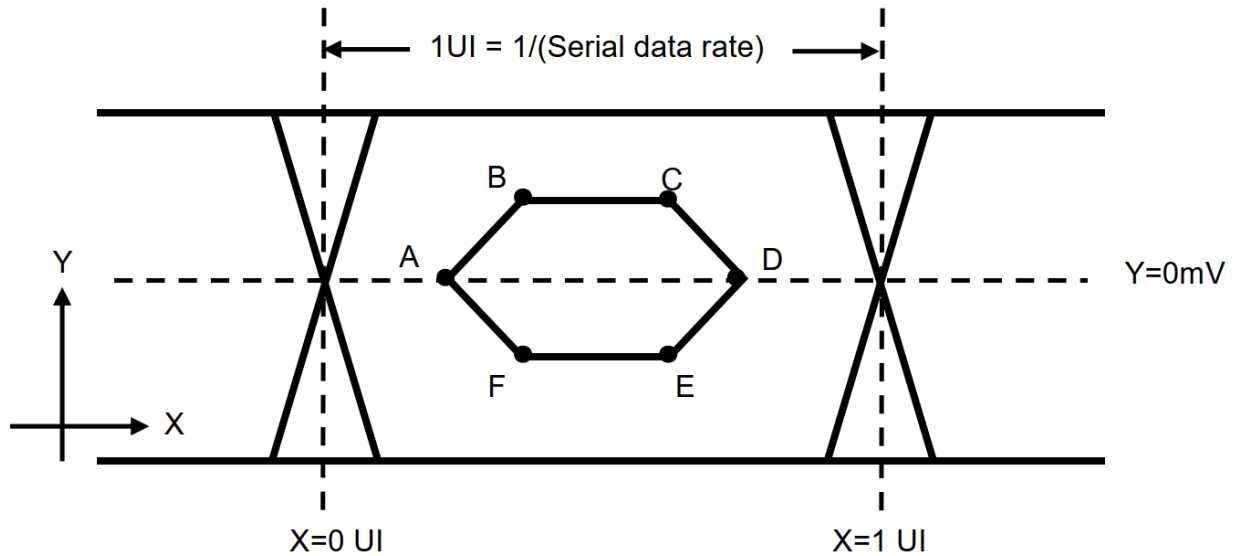

Eye Mask Specification

	X[UI]	Note	Y[mV]	Note
A	0.25 (max)	2	0	-
B	0.3 (max)	2	50	3
C	0.7(min)	3	50	3
D	0.75(min)	3	0	-
E	0.7(min)	3	-50	3
F	0.3(max)	2	-50	3

Notes:

1. All Input levels of V by One signals are based on the V by One HS Standard Ver. 1.4
 2. This is allowable maximum value.
 3. This is allowable minimum value.
 4. The eye diagram is measured by the oscilloscope and receiver CDR characteristic must be emulated.
- PLL bandwidth: 15Mhz
 -Damping Factor: 1

V by One Input Signal Characteristics

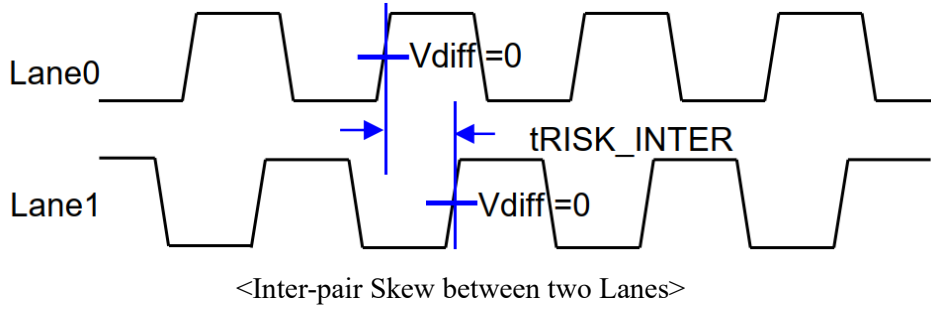

Description	Symbol	Min	Max	Unit	notes
Allowable inter-pair skew between lanes	tRISK_INTER	-	5	UI	1,2

Notes:

- 1.1UI = 1/serial data rate
2. It is the time difference of the differential voltage between any two lanes in one sub block

2.5 Intra Interface Signal Specification

EPI Signal Specification

Parameter	Symbol	Condition	MIN	TYP	MAX	Unit	notes
Logic & EPI Power Voltage	VCC	-	1.62	1.8	1.98	Vdc	
EPI input common voltage	VCM	CML Type	0.8	-	1.2-Vdiff/2	V	
EPI input differential voltage	Vdiff	-	150	-	500	mV	
EPI Input eye diagram	Veye	-	90	-	-	mV	
Effective Veye width time	B1&B2	-	0.25	-	-	UI	

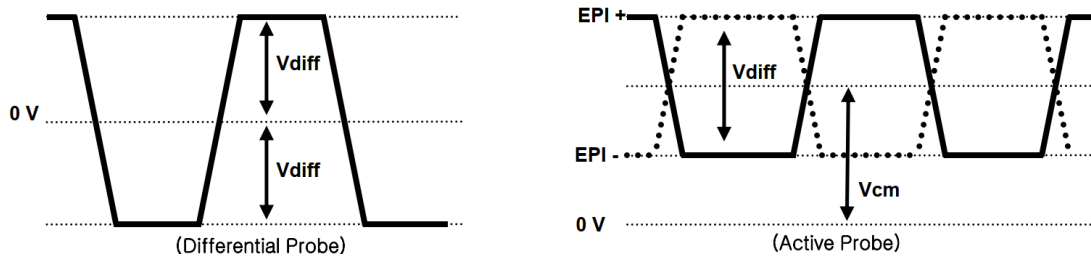

EPI Differential signal characteristics

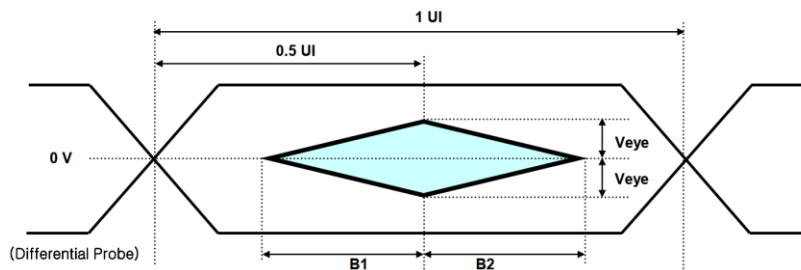

Eye Pattern of EPI Input
*Source PCB

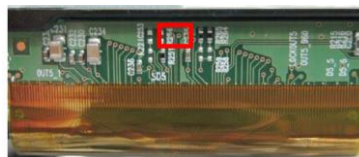

FIG.1 Measure point

2.6 Color Data Reference

The brightness of each primary color (red, green, blue) is based on the 10bit or 8bit gray scale data input for the color. The higher binary input, the brighter the color. The table provides a reference for color versus data input.

Packer input & Unpacker output		30bpp RGB (10bit)	24bpp RGB (8bit)
Byte0	D[0]	R[2]	R[0]
	D[1]	R[3]	R[1]
	D[2]	R[4]	R[2]
	D[3]	R[5]	R[3]
	D[4]	R[6]	R[4]
	D[5]	R[7]	R[5]
	D[6]	R[8]	R[6]
	D[7]	R[9]	R[7]
Byte1	D[8]	G[2]	G[0]
	D[9]	G[3]	G[1]
	D[10]	G[4]	G[2]
	D[11]	G[5]	G[3]
	D[12]	G[6]	G[4]
	D[13]	G[7]	G[5]
	D[14]	G[8]	G[6]
	D[15]	G[9]	G[7]
Byte2	D[16]	B[2]	B[0]
	D[17]	B[3]	B[1]
	D[18]	B[4]	B[2]
	D[19]	B[5]	B[3]
	D[20]	B[6]	B[4]
	D[21]	B[7]	B[5]
	D[22]	B[8]	B[6]
	D[23]	B[9]	B[7]
Byte4	D[24]	Don't care	
	D[25]	Don't care	
	D[26]	B[0]	
	D[27]	B[1]	
	D[28]	G[0]	
	D[29]	G[1]	
	D[30]	R[0]	
	D[31]	R[1]	

2.7 Power Sequence

LCD Driving Circuit

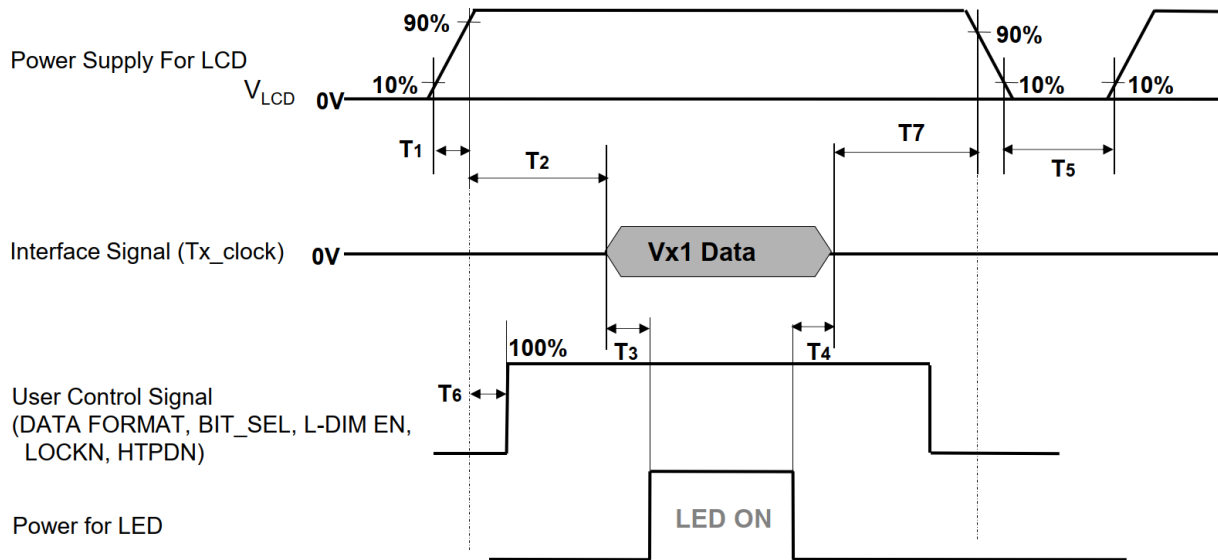

Power Sequence

Parameter	Value			Unit	Note
	Min	Typ	Max		
T1	0.5	-	20	ms	1
T2	0	-	-	ms	2
T3	400	-	-	ms	3
T4	100	-	-	ms	3
T5	3.0	-	-	s	4
T6	0	-	T2	ms	5
T7	0	-	-	ms	6

Notes:

- Even though T1 is over the specified value, there is no problem if I2T spec of fuse is satisfied. In case that VCC is in off level, please keep the level of input signals on the low or high impedance. If $T_2 < 0$, that may cause electrical overstress.
 - If T2 is satisfied with specification after removing LVDS Cable, there is no problem. Interface signal shall not be kept at high impedance when the power is on.
 - The T3/T4 is recommended value, the case when failed to meet a minimum specification, abnormal display would be shown. There is no reliability problem.
 - T5 should be measured after the Module has been fully discharged between power off and on period.
 - If the on time of signals (Interface signal and user control signals) precedes the on time of Power (V_{LCD}), it will be happened abnormal display. When T6 is NC status, T6 doesn't need to be measured.
 - It is recommendation specification that T7 has to be 0ms as a minimum value.
- ※Please avoid floating state of interface signal at invalid period.
- ※When the power supply for LCD (V_{LCD}) is off, be sure to pull down the valid and invalid data to 0V.

3 Optical Specification

Item		Symbol	Condition	Min.	Typ.	Max.	Unit	Note
Color chromaticity	Red	Rx	$\theta_x=0$ $\theta_y=0$ CA-410	0.618	0.648	0.678	-	Test Mode: (2) (3)
		Ry		0.303	0.333	0.363	-	
	Green	Gx		0.290	0.320	0.350	-	
		Gy		0.577	0.607	0.637	-	
	Blue	Bx		0.122	0.152	0.182	-	
		By		0.040	0.070	0.100	-	
	White	Wx		0.261	0.291	0.321	-	
		Wy		0.286	0.316	0.346	-	
Center Luminance of White		Lc	$\theta_x=0$	630	700	910	cd/m ²	
Uniform		Lu	$\theta_y=0$ CA-410		87		%	
Contrast Ratio		CR	$\theta_x=0$	1080:1	1200:1		-	Test Mode: (4)
Color Saturation		NTSC	$\theta_y=0$ Klein K-10		82		%	
Viewing Angle	Horizontal	θ_{x+}	CR \geq 10		89		Deg	Test Mode: (1)
		θ_{x-}			89			
	Vertical	θ_{y+}			89			
		θ_{y-}			89			

Test Mode :

(1) Definition of Viewing Angle (θ_x , θ_y):

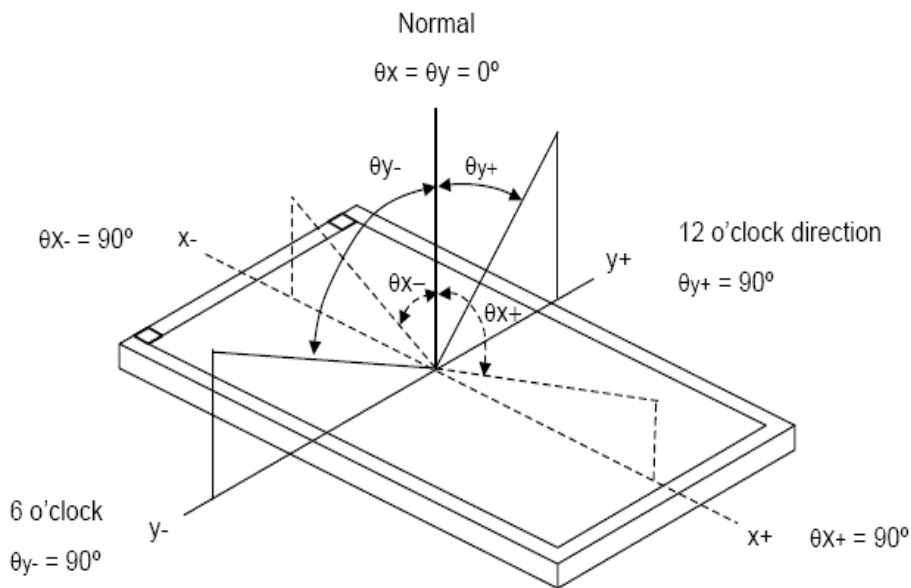

(2) Definition of Test Point:

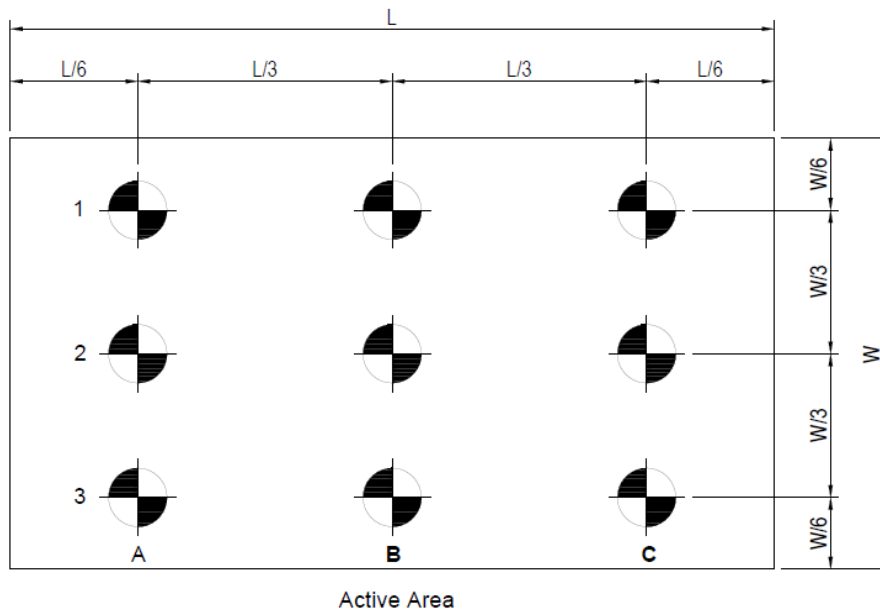

(3) CA-410 Measurement Setup:

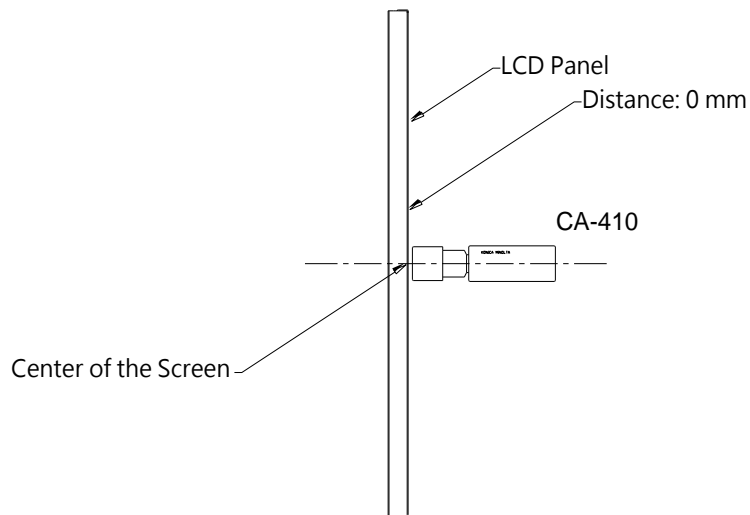

(4) Klein K-10 Measurement Setup:

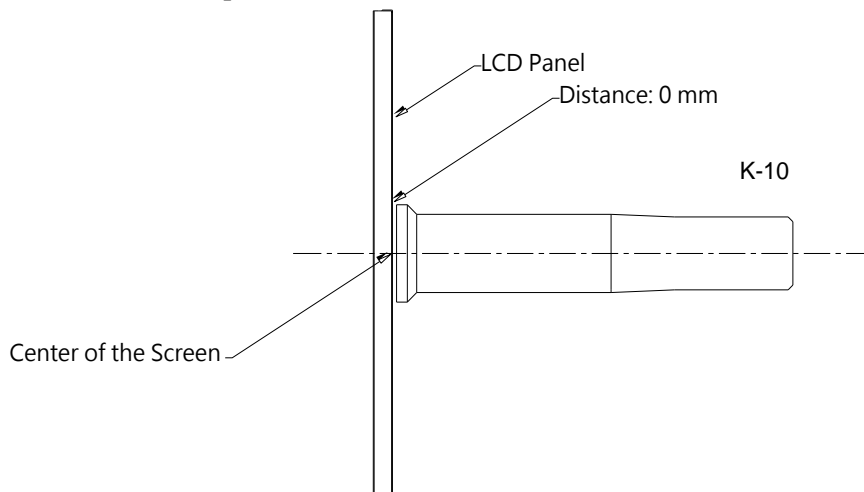

4 LED Driving Board Specifications

4.1 Operating Characteristics

Parameter		Min.	Typ.	Max.	Unit
Input Voltage	Vin	23.5	24	25	V
Input Current	Iin	4	5	6	A
Output Current(Per Group)	Iout		900ma		mA
Output Voltage	Vout		131V		V
Output Power	Wout		118		Watt
Efficiency	Eff	-	78	-	%
LED ON/OFF	Von	2.5	-	5.0	V
	Voff	0	-	2.5	V
PWM	PWM	2.5		5	V

4.2 Connector Socket

Input Connector: CN1A: 14pin wafer, pitch 2.0mm

Pin	Symbol	Description
1	+24V	Power Supply 23.5~25V
2	+24V	Power Supply 23.5~25V
3	+24V	Power Supply 23.5~25V
4	+24V	Power Supply 23.5~25V
5	+24V	Power Supply 23.5~25V
6	GND	Power Supply Ground
7	GND	Power Supply Ground
8	GND	Power Supply Ground
9	GND	Power Supply Ground
10	GND	Power Supply Ground
11	N/C	Non-Connection
12	N/F	Standby/Operation/ Turn on/off backlight, On=2.5-5V , Off =0-2.5V
13	PWM	Dimming control, 100%=Brightness Max, 0%=Brightness Min
14	N/C	Short with Pin 13

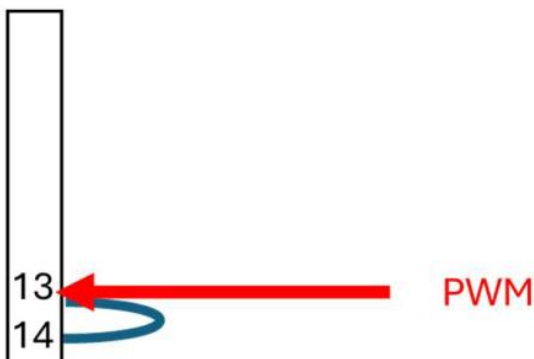

Input Connector: CN1B: 14pin wafer, pitch 2.0mm

Pin	Symbol	Description
1	+24V	Power Supply 23.5~25V
2	+24V	Power Supply 23.5~25V
3	+24V	Power Supply 23.5~25V
4	+24V	Power Supply 23.5~25V
5	+24V	Power Supply 23.5~25V
6	GND	Power Supply Ground
7	GND	Power Supply Ground
8	GND	Power Supply Ground
9	GND	Power Supply Ground
10	GND	Power Supply Ground
11	N/C	Non-Connection
12	N/C	Non-Connection
13	N/C	Non-Connection
14	N/C	Short with Pin 13

Note:

The structural design of the backlight module requires the two LED driver board to supply constant current simultaneously. Therefore, one interface needs to be connected to the 24.0V pin, ground pin, switch pin and dimming pin, while the other interface only needs to be connected to the 24.0V and ground. The two interfaces can be interchanged and connected.

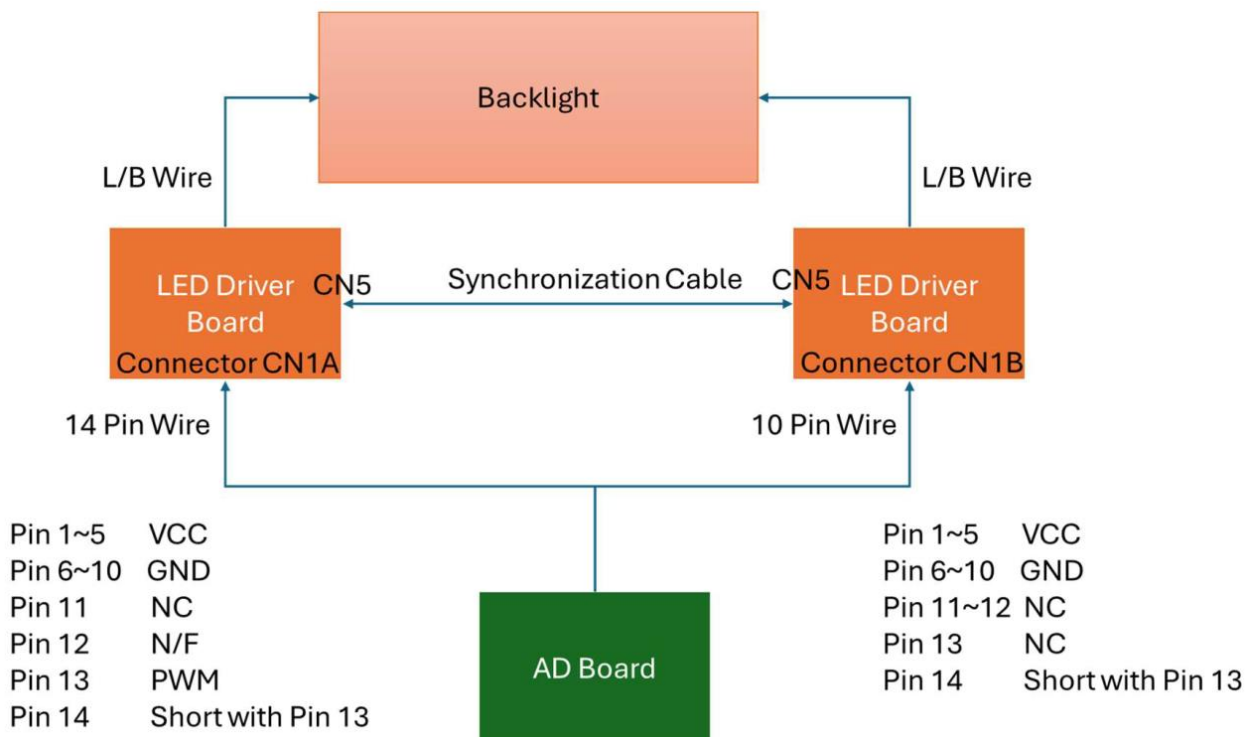

4.3 Mechanical Characteristics

Dimension: 150.0 x 150.0 x 11.0mm

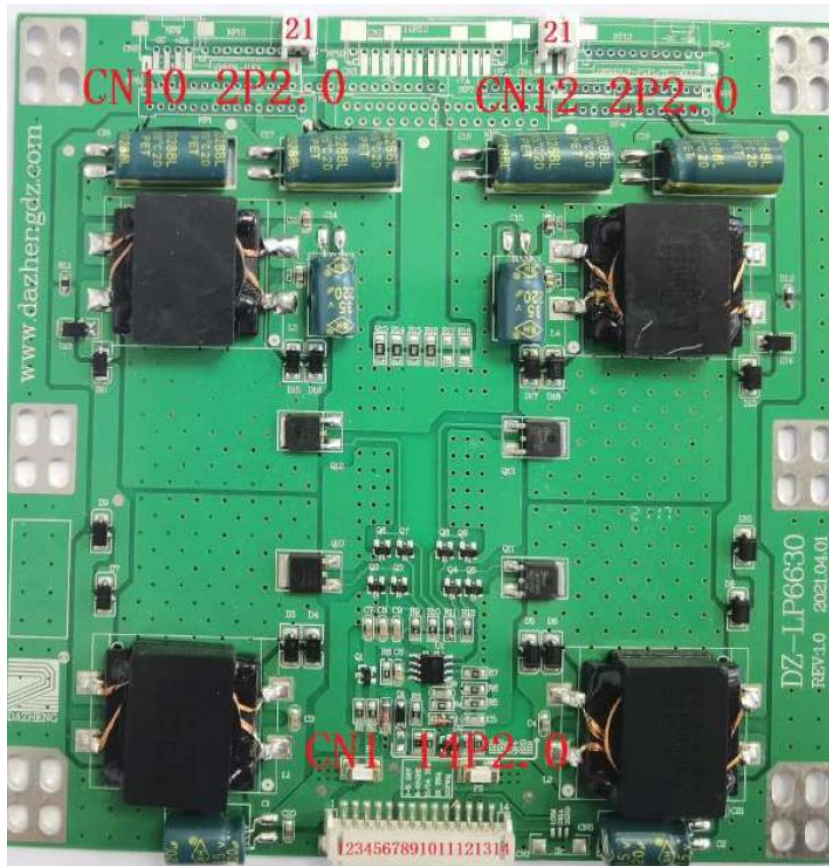
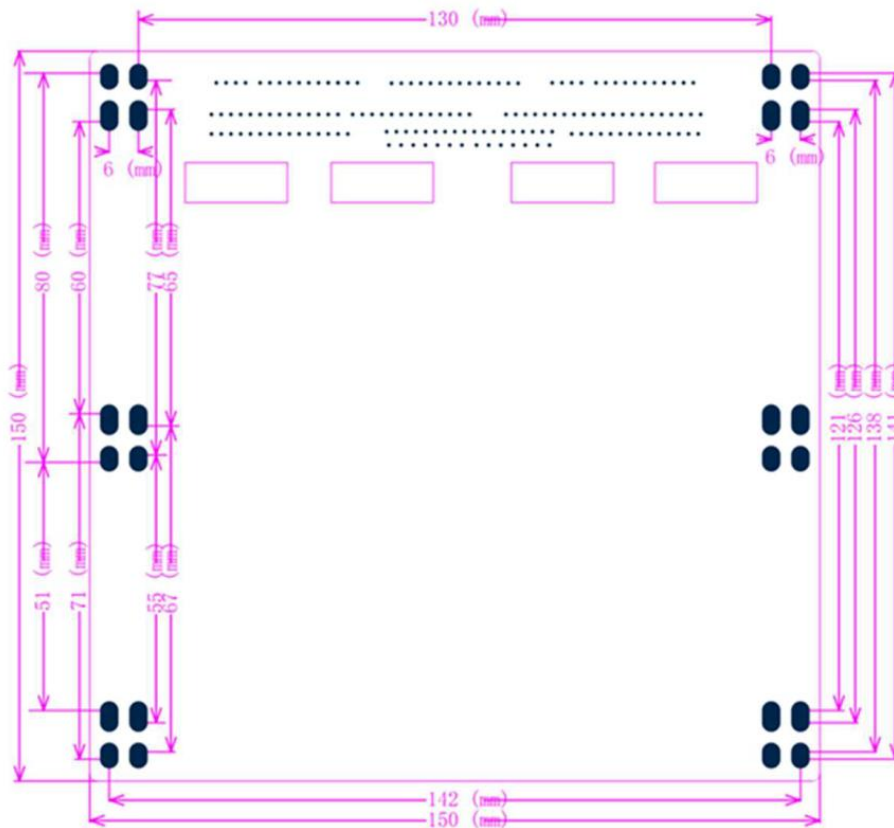

5 Mechanical Drawing

Outline Dimensions

Unit: mm

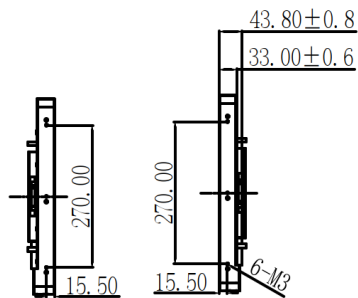
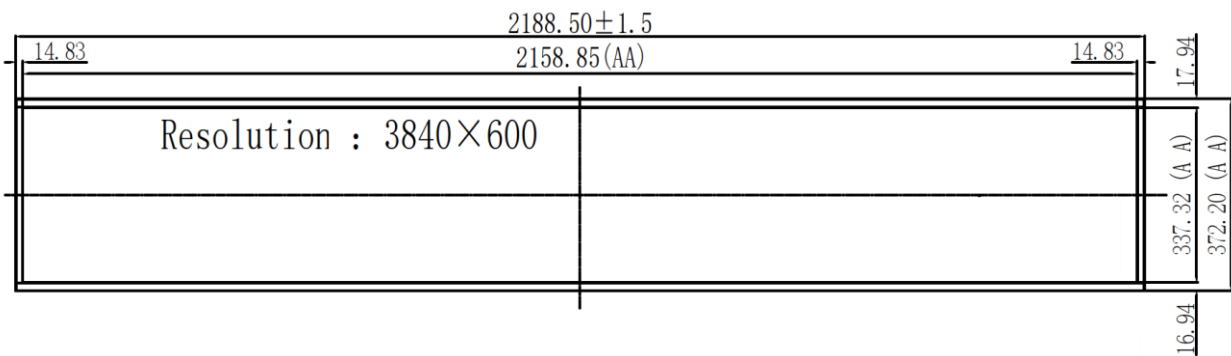
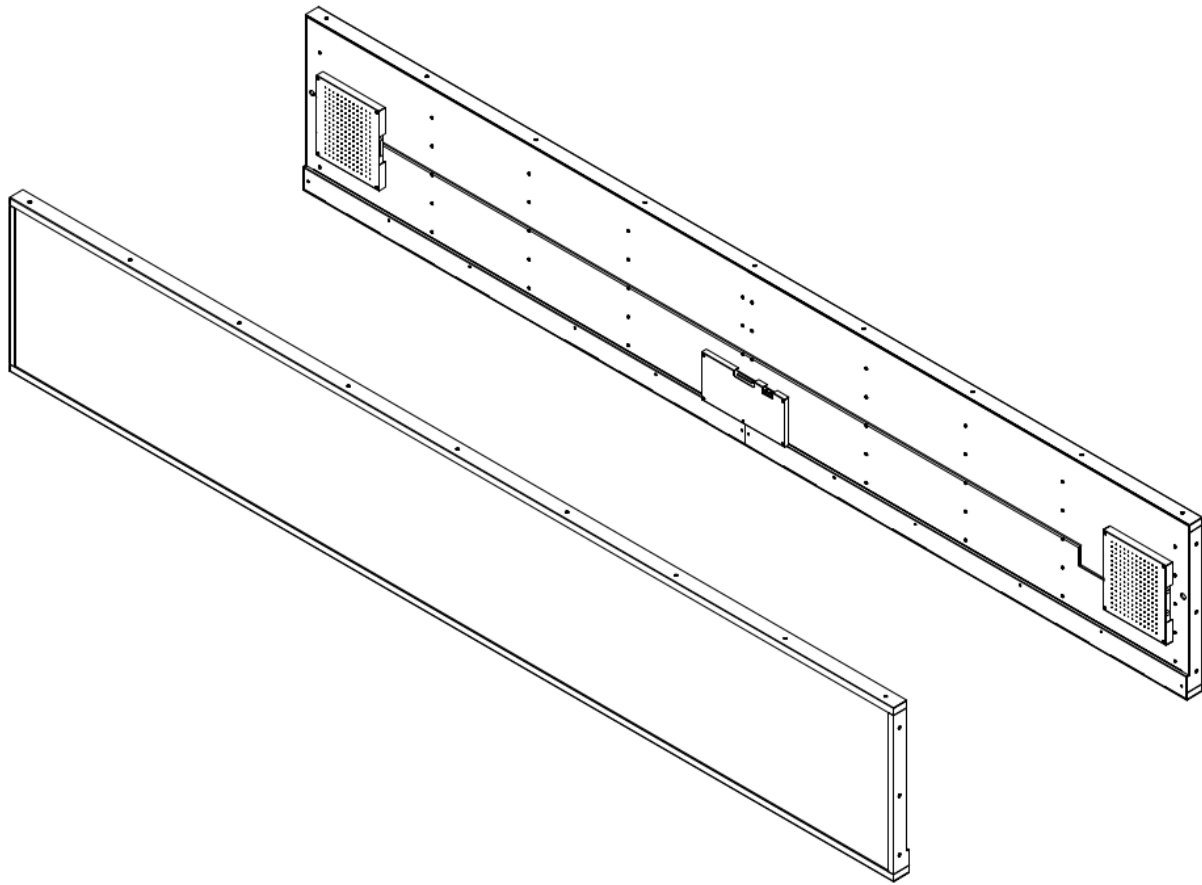

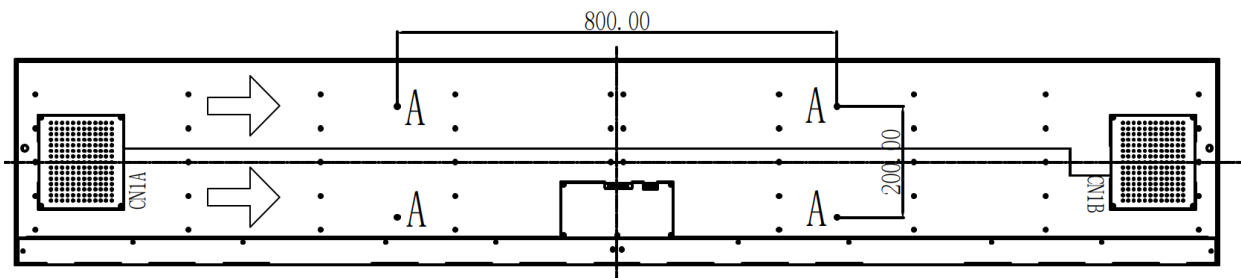
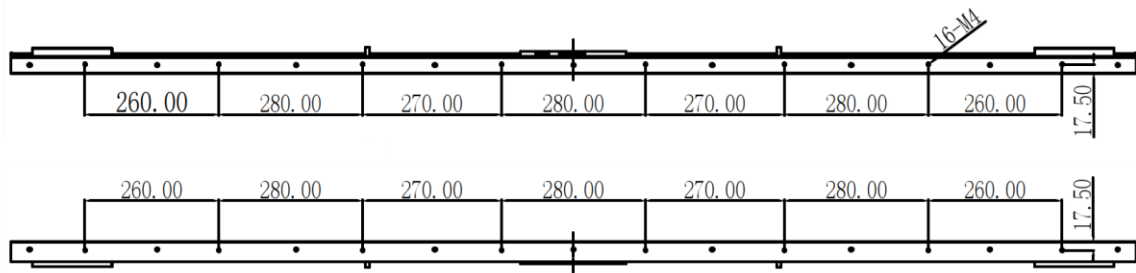

Note: "A" BSO-M4x20 and BOSS 4pcs

6 AD9800HP Board & OSD Functions

AD9800 is a good performance AD board for Litemax 4K resolution display product. Input interface supports HDMI, DP. Output supports V-by-1 and eDP panel. Max resolution up to 3840x2160.

For high level application, AD9800 supports screen rotation by embedded frame buffer.

General Description

- Max resolution 3840x2160 60Hz
- One HDMI 2.1, supports 3840x2160 60Hz.
- One Display port 1.4, supports 3840x2160 60Hz.
- Support 90, 180, degree rotation.
- Embedded MCU with ADC port for VR, light sensor application.
- Support HDCP 2.3.
- Audio line in and speaker output.
- Embedded OSD.
- Support V-by-1, eDP panel.
- Support up to 64 zones LED local dimming control.

Characteristics

Power Input	12V/24V (Note1)
Power Consumption	15W Max. (Note2)
Input interface	HDMI 2.1, DP 1.4
Output interface	V-by-1 8 lanes, eDP 8 lanes.
Resolution	Max 3840x2160.
Support panel voltage	5 / 10 / 12 V
Speaker	5W speaker x 2(8Ω)
Backlight control	EN and PWM or DC dimming for backlight
Operation Temperature	-20 ~ 70 degree C

Note1: 12V or 24V are two different PCBA version, selection should be noted.

Note2: 15W means AD board own consumption, not include LCD and T-con.

Outline Dimensions
AD9800HP 150mm x 100mm

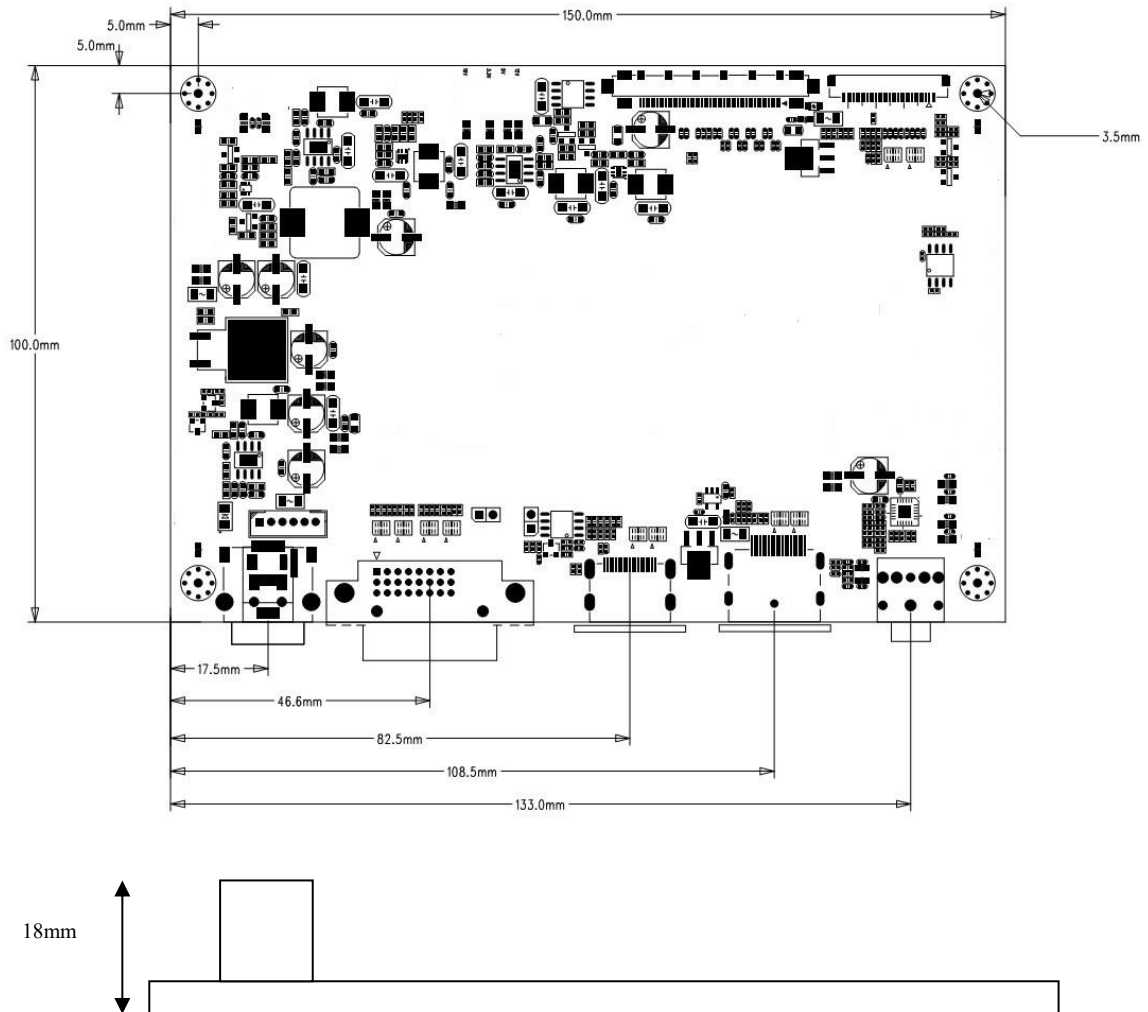
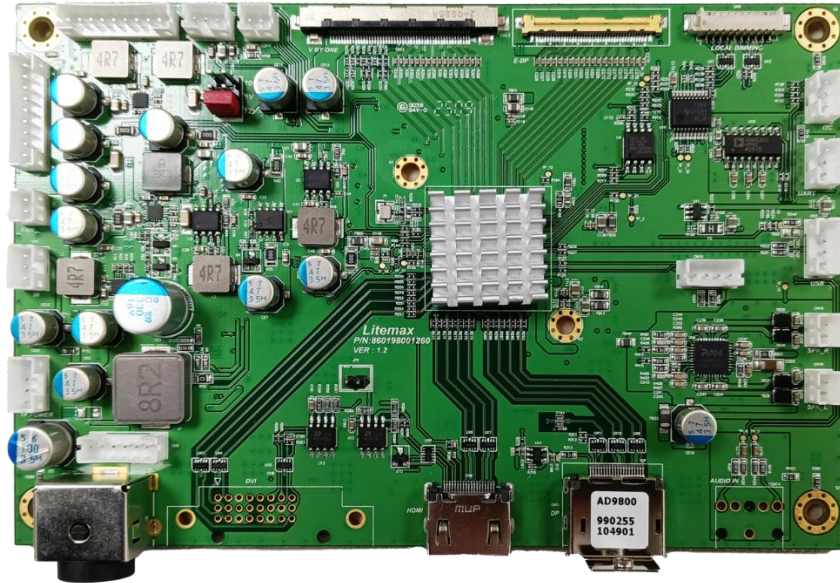

AD9800HP Board Pin Define

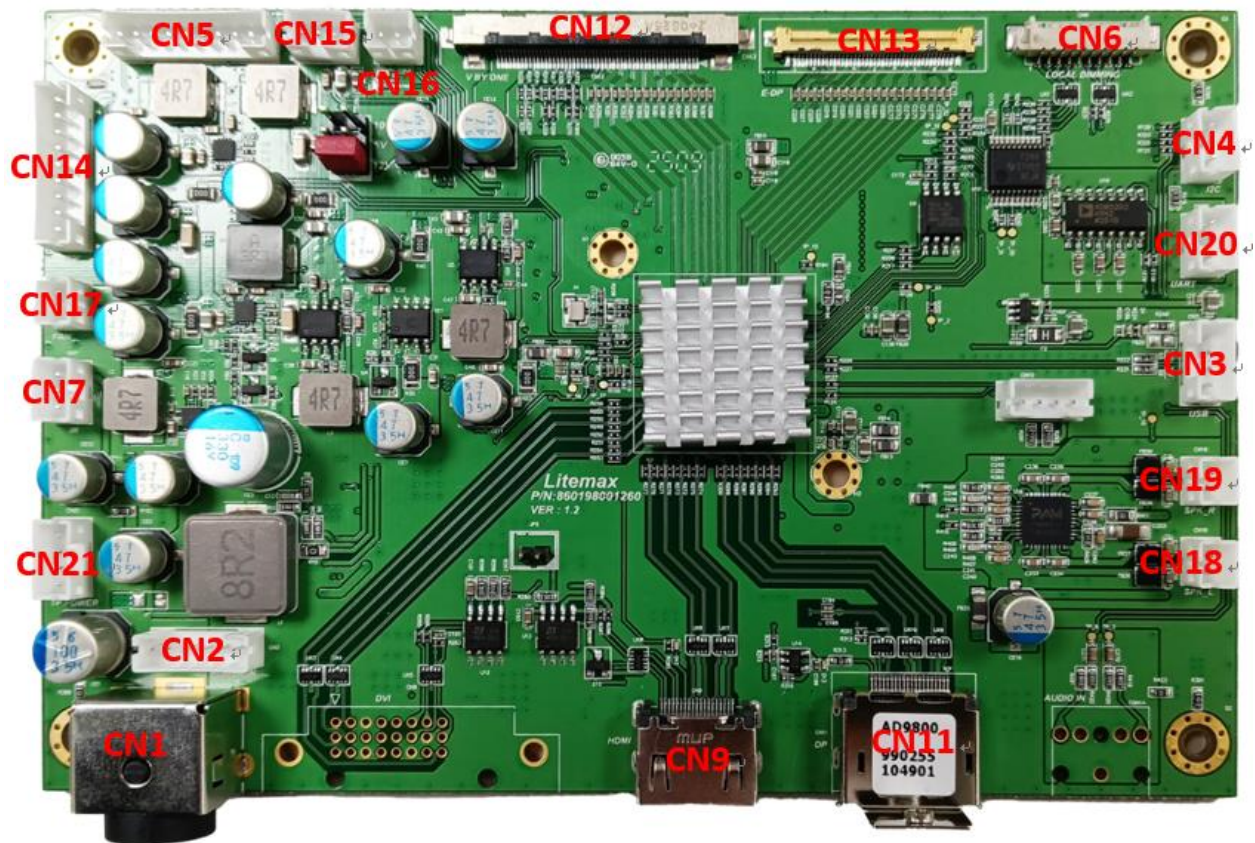

Connector pin define

➤ CN12: V-by-one output

Pin	Function	Pin	Function
1	GND	27	HPD
2	X7P	28	8b/10b SEL
3	X7N	29	NC
4	GND	30	LD_EN_U
5	X6P	31	NC
6	X6N	32	NC
7	GND	33	SCL
8	X5P	34	SDA
9	X5N	35	3D_EN_U
10	GND	36	NC
11	X4P	37	NC
12	X4N	38	GND
13	GND	39	GND
14	X3P	40	GND
15	X3N	41	GND
16	GND	42	GND

17	X2P	43	NC
18	X2N	44	Panel power
19	GND	45	Panel power
20	X1P	46	Panel power
21	X1N	47	Panel power
22	GND	48	Panel power
23	X0P	49	Panel power
24	X0N	50	Panel power
25	GND	51	Panel power
26	LOCKN		

➤ CN9: HDMI input

Pin	Function	Pin	Function	Pin	Function
1	TMDS Data2+	9	TMDS Data0-	17	GND
2	Shield	10	TMDS Clock+	18	HDMI +5V
3	TMDS Data2-	11	Shield	19	HPD
4	TMDS Data1+	12	TMDS Clock-		
5	Shield	13	CEC		
6	TMDS Data1-	14	NC		
7	TMDS Data0+	15	HDMI_SCL		
8	Shield	16	HDMI_SDA		

➤ CN11: DisplayPort input

Pin	Function	Pin	Function
1	LAN_C_D3N	11	GND
2	GND	12	ML_LANE0_P
3	LAN_C_D3P	13	GND
4	ML_LANE2_N	14	GND
5	GND	15	AUX_CH_P
6	ML_LANE2_P	16	GND
7	ML_LANE1_N	17	AUX_CH_N
8	GND	18	Hot plug detect
9	ML_LANE1_P	19	GND
10	ML_LANE0_N	20	DP +5V

➤ CN1: Power input (Power Din 4 pin)

Pin	Function	Pin	Function
1	Power Input	3	GND
2	Power Input	4	GND

➤ CN1: Power input (Power Jack 3 pin)

Pin	Function	Pin	Function
1	Power Input	3	GND
2	GND		

➤ CN2: Power input (Wafer 2.0mm pitch 6 pin)

Pin	Function	Pin	Function
1	Power Input	4	GND
2	Power Input	5	GND
3	Power Input	6	GND

➤ CN21: Reserved 12/5V (Wafer 2.0mm pitch 4 pin)

Pin	Function	Pin	Function
1	5V	3	12V
2	GND	4	GND

➤ CN14: Backlight Power and Control (Wafer 2.0mm pitch 9 pin)

Pin	Function	Pin	Function
1	DC/PWM SEL	6	GND
2	Enable	7	12V (Note3)
3	Dimming	8	12V (Note3)
4	GND	9	12V (Note3)
5	GND		

Note3: Pin 7,8,9 are for 12V version only. If you choose 24V version, these 3 pin are NC.

➤ CN17: 12V for Fan power (Wafer 2.0mm pitch 2 pin)

Pin	Function	Pin	Function
1	Fan+ (12V)	2	Fan-

➤ CN5: Keypad (Wafer 2.0mm pitch 9 pin)

Pin	Function	Pin	Function
1	POWER KEY	6	MENU KEY
2	GREEN LED	7	AUTO KEY
3	RED LED	8	GND
4	DOWN KEY	9	GND
5	UP KEY		

➤ CN15: VR (Wafer 2.0mm pitch 3 pin)

Pin	Function	Pin	Function
1	3.3V	3	GND
2	VR		

➤ CN16: Light sensor (Wafer 2.0mm pitch 2 pin)

Pin	Function	Pin	Function
1	5V/3.3V	2	Sensor Out

➤ JP1: Panel power selection (2.54mm pitch 2x3 jump)

Pin	Function	Pin	Function
1-2 close	12V	5-6 close	10V
3-4 close	5V		

➤ CN18,CN19: Speaker output (Wafer 2.0mm pitch 2 pin)

Pin	Function	Pin	Function
1	SPK+	2	SPK-

➤ CN20: UART (Wafer 2.0mm pitch 3 pin)

Pin	Function	Pin	Function
1	TX	3	GND
2	RX		

➤ CN4: I2C (Wafer 2.0mm pitch 3 pin)

Pin	Function	Pin	Function
1	SDA	3	GND
2	SCL		

➤ CN13: eDP output

Pin	Function	Pin	Function
1	GND	21	GND
2	NC	22	EDP-D1-
3	GND	23	EDP-D1+
4	EDP-D7-	24	GND
5	EDP-D7+	25	EDP-D0-
6	GND	26	EDP-D0+
7	EDP-D6-	27	GND
8	EDP-D6+	28	AUXTX_1P
9	GND	29	AUXTX_1N
10	EDP-D5-	30	GND
11	EDP-D5+	31	AUXTX_0P

12	GND	32	AUXTX_ON
13	EDP-D4-	33	GND
14	EDP-D4+	34	eHPD1
15	GND	35	eHPD0
16	EDP-D3-	36	NC
17	EDP-D3+	37	Panel power
18	GND	38	Panel power
19	EDP-D2-	39	Panel power
20	EDP-D2+	40	Panel power

➤ CN3: USB (Wafer 2.0mm pitch 4 pin)

Pin	Function	Pin	Function
1	USB_5V	3	D0+
2	D0-	4	GND

Note: CN3 only for update FW.

➤ CN6: Local Dimming (Wafer 1.25mm pitch 10 pin)

Pin	Function	Pin	Function
1	LDSPiO_SDI_OUT	6	LD_VSYNC_OUT
2	LDSPiO_SDO_OUT	7	LD_HSYNC_OUT
3	LDSPiO_SCL_OUT	8	GND
4	LDSPiO_CS_OUT	9	VBLCTRL
5	GND	10	NC

➤ JP2: EDID Write Protect (Wafer 2.0mm pitch 2 pin)

Pin	Function	Pin	Function
1	3.3V	2	GND

Note: When update EDID , this JP2 must be short.





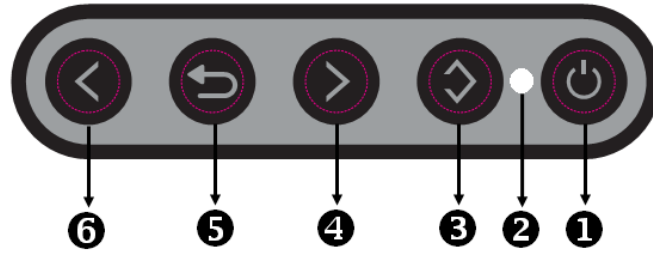

➤ CON14: Phone Jack(Optional)

Pin	Function	Pin	Function
1	GND	4	GND
2	Audio IN_R	5	GND
3	Audio IN_L		

6.1 OSD Function

MEMBRANE CONTROL BUTTOM



- ①  **Key:** (Power) function key
Press the power switch will turn the monitor on.
Press it again to turn the monitor off.
- ②  **LED Status:** Power ON-Green / Power OFF-No.
- ③  **Key:** (Menu + Selection Right + Enter) function key
Press this button to the OSD “main menu”. And then press this button go to the “Selection Right” function, and press again this button to “Enter”.
- ④  **Key:** (Menu + Selection Up + Increase) function key
Press this button to the OSD “main menu”. And then press this button go to the “Selection Up” function, and press again this button to adjustment value “Increase”.
- ⑤  **Key:** (Menu + Exit) function key
Enter to the OSD adjustment menu. It also used for go back to previous menu for sub-menu.
- ⑥  **Key:** (Menu + Selection Down + Decrease) function key
Press this button to the OSD “main menu”. And then press this button go to the “Selection Down” function, and press again this button to adjustment value “Decrease”.

Screen Adjustment Operation Procedure

1. Entering the screen adjustment

The setting switches are normally at stand-by. Push the **Menu Key** once to display the main menu of the screen adjustment. The adjustable items will be displayed in the main menu.

2. Entering the settings

Use the **Down Key**  and **Up Key**  buttons to select the desired setting icon and push the SELECT button to enter sub-menu.

3. Change the settings

After the sub-menu appears, use the **Down Key**  and **Up Key**  buttons to change the setting values.

4. Save

After finishing the adjustment, push the  button to memorize the setting.

5. Return & Exit the Main Menu

Exit the screen adjustment; push the “MENU” button. When no operation is done around 30 sec (default OSD timeout), it goes back to the stand-by mode and no more switching is accepted except MENU to restart the setting.

6.2 OSD Menu

By pressing the “menu” button, you will see the below picture. Across from timing you will see resolution, frequency, and V-frequency of the panel. These cannot be altered by the user.



7 Precautions

7.1 Handling and Mounting Precautions

- (1) The module should be assembled into the system firmly by using every mounting hole. Do not apply rough force such as bending or twisting to the LCD during assembly.
- (2) You should consider the mounting structure so that uneven force (ex. Twisted stress, Concentrated stress) is not applied to the module. And the case on which a module is mounted should have sufficient strength so that external force is not transmitted directly to the LCD module.
- (3) While assembling or installing LCD modules, it can only be in the clean area. The dust and oil may cause electrical short or damage the polarizer.
- (4) Use fingerstalls or soft gloves in order to keep display clean during the incoming inspection and assembly process.
- (5) Do not press or scratch the surface harder than a HB pencil lead on the panel because the polarizer is very soft and easily be scratched.
- (6) Please attach the surface transparent protection film to the surface in order to protect the polarizer. Transparent protection film should have sufficient strength in order to the resist external force.
- (7) When the transparent protection film is peeled off, static electricity is generated between the film and polarizer. This should be peeled off slowly and carefully by people who are electrically grounded and with well ion-blown equipment or in such a condition, etc.
- (8) If the surface of the polarizer is dirty, please clean it by some absorbent cotton or soft cloth. Do not use Ketone type materials (ex. Acetone), Ethyl alcohol, Toluene, Ethyl acid or Methyl chloride. It might permanently damage the polarizer due to chemical reaction.
- (9) Wipe off water droplets or oil immediately. Staining and discoloration may occur if they left on panel for a long time.
- (10) If the liquid crystal material leaks from the panel, it should be kept away from the eyes or mouth. In case of contacting with hands, legs or clothes, it must be washed away thoroughly with soap.
- (11) Protect the LCD module from static electricity, it may cause damage to the C-MOS Gate Array IC.
- (12) Do not disassemble the module.
- (13) Do not pull or fold the lamp wire.
- (14) Pins of I/F connector should not be touched directly with bare hands.

7.2 Storage Precautions

- (1) High temperature or humidity may reduce the performance of LCD module. Please store LCD module within the specified storage conditions.
- (2) If possible store them in a dark place. Do not expose the module to sunlight or fluorescent light. Keep the temperature between 5°C and 35°C at normal humidity.
- (3) It is dangerous that moisture come into or contacted the LCD module, because the moisture may damage LCD module when it is operating.
- (4) The polarizer surface should not come in contact with any other object. It is recommended that they be stored in the container in which they were shipped.

7.3 Operation Precautions

- (1) Do not pull the I/F connector in or out while the LCD module is operating.
- (2) Always follow the correct power on/off sequence when LCD module is connecting and operating. This can prevent the CMOS LSI chips from damage during latch-up.
- (3) Response time depends on the temperature. (In lower temperature, it becomes longer.)
- (4) Brightness depends on the temperature. (In lower temperature, it becomes lower.)
- (5) Be careful for condensation at sudden temperature change. Condensation makes damage to polarizer or electrical contacted parts. And after fading condensation, smear or spot will occur.
- (6) Module has high frequency circuits. Sufficient suppression to the electromagnetic interference shall be done by system manufacturers. Grounding and shielding methods are very important to minimize the interference.
- (7) Please do not give any mechanical and/or acoustical impact to module. Otherwise, module can't be operated its full characteristics perfectly.
- (8) Since a module is composed of electronic circuits, it is not strong to electrostatic discharge. Make certain that treatment persons are connected to ground through wrist band etc. And don't touch interface pin directly.
- (9) Do not display the fixed pattern for a long time because it may cause image sticking.
- (10) In order to prevent image sticking, periodical power-off or screen save is needed after fixed pattern long time display.
- (11) Black image or moving image is strongly recommended as a screen save.
- (12) Static information display recommended to use with moving image. Cycling display between 10 minutes' information (static) display and 10 seconds' moving image.
- (13) Background and character (image) color change is recommended. Use different colors for background and character, respectively. And change colors themselves periodically.
- (14) LCD system is required to place in well-ventilated environment. Adapting active cooling system is highly recommended.
- (15) Product reliability and functions are only guaranteed when the product is used under right operation usages.
- (16) If product will be used in extreme conditions, such as high temperature/ humidity, shock and vibration it is strongly recommended to contact Litemax for filed application engineering advice. Otherwise, its reliability and function may not be guaranteed. Extreme conditions are commonly found at airports, transit stations, taxi-top, in vehicle and controlling systems.

8 Disclaimer

All information in this document are subject to change, please constant LiteMax for any new design.